

---

---

# THE BLENDING OF COALS FOR COKING

Report from  
THE COAL BLENDING & COKING RESEARCH  
SUB-COMMITTEE



JEL RESEARCH COMMITTEE  
BOARD OF SCIENTIFIC & INDUSTRIAL RESEARCH  
REPORT No. 2

1948

---

---

COUNCIL OF SCIENTIFIC & INDUSTRIAL RESEARCH

# **THE BLENDING OF COALS FOR COKING**

Report from

**THE COAL BLENDING & COKING RESEARCH  
SUB-COMMITTEE**



**FUEL RESEARCH COMMITTEE  
BOARD OF SCIENTIFIC & INDUSTRIAL RESEARCH**

**REPORT No. 2**

**1948**

---

**COUNCIL OF SCIENTIFIC & INDUSTRIAL RESEARCH**

# CONTENTS

	Page
FUEL RESEARCH COMMITTEE (1947) .. .. .	v
COAL BLENDING & COKING RESEARCH COMMITTEE (1947) .. .. .	v
STAFF .. .. .	vi
INTRODUCTION .. .. .	vii
 <b>CHAPTER I</b>	
<i>Testing of Coal &amp; Coke</i>	
1. General Procedure .. .. .	1
2. Laboratory Tests .. .. .	2
3. Pilot or Semi-large-scale Tests .. .. .	9
4. Large-scale Tests .. .. .	13
5. Specification for Indian Metallurgical Coal & Coke .. .. .	14
6. Grading of Indian Coals .. .. .	14
7. Coking Properties of Coals .. .. .	15
 <b>CHAPTER II</b>	
<i>Summary of Experimental Results</i>	
1. Jharia Coals — Swelling Tests .. .. .	22
2. Jharia Coalfield — Seams below Seam 10 .. .. .	22
3. Coals from the Raniganj Coalfield .. .. .	23
4. Coals from the Central Provinces, Korea & Rewa States .. .. .	24
5. Coals from South Karanpura .. .. .	24
6. Coals from Hyderabad (Deccan) .. .. .	24
7. Coals from Madras .. .. .	24
8. Coals from Assam .. .. .	24
9. Coals from Australia .. .. .	25
10. Special Tests .. .. .	25
 <b>CHAPTER III</b>	
<i>Discussions &amp; Conclusions</i>	
1. Caking Index .. .. .	26
2. Moisture Content .. .. .	26
3. Swelling Properties .. .. .	26
4. Blending Results .. .. .	27
5. Jharia Coalfield — Seams below Seam 10 .. .. .	27
6. Raniganj Coals .. .. .	27
7. Central Provinces Coals .. .. .	27
8. Assam Coals .. .. .	28
9. Use of Coke-breeze in Blends .. .. .	28
 <b>APPENDIX</b>	
Tables of Results of Laboratory & Plant Tests .. .. .	35

# COUNCIL OF SCIENTIFIC & INDUSTRIAL RESEARCH

## FUEL RESEARCH COMMITTEE (1947)

A. FARQUHAR, ESQ.	..	..	Chairman
DR. C. FORRESTER	..	..	Member
DR. W. D. WEST	..	..	"
DR. D. N. WADIA	..	..	"
DEWAN BAHADUR D. D. THACKER	..	..	"
R. F. ORME, ESQ.	..	..	"
SIR J. C. GHOSE	..	..	"
K. B. SEN, ESQ.	..	..	"
PROF. N. N. CHATTERJEE	..	..	"
N. BARRACLOUGH, ESQ.	..	..	"
SIR S. S. BHATNAGAR	..	..	Ex-Officio
DR. J. W. WHITAKER	..	..	"
DR. A. LAHIRI	..	..	Secretary

## COAL BLENDING & COKING RESEARCH SUB-COMMITTEE (1947)

E. T. WARREN, ESQ.	..	..	Chairman
A. C. BOSE, ESQ.	..	..	Member
N. SEN, ESQ.	..	..	"
S. ROY, ESQ.	..	..	Ex-Officio
S. N. SIRCAR, ESQ.	..	..	"
B. KRISHNAMURTY, ESQ.	..	..	"
N. N. DAS GUPTA, ESQ.	..	..	Ag. Secretary

The following have also served on the Coal Blending & Coking Research Sub-Committee at different times :

A. FARQUHAR, ESQ.	..	..	Chairman
M. P. KANGA, ESQ.	..	..	Secretary
K. V. RAMCHANDRAM, ESQ.	..	..	"
H. M. GHOSH, ESQ.	..	..	Ex-Officio Member
H. F. DAMKEWALLA, ESQ.	..	..	"
N. R. ANANTIER, ESQ.	..	..	"

## S T A F F

N. N. DAS GUPTA	..	..	Fuel Technologist
N. G. BANERJEE	..	..	Chemist
R. N. MITRA	..	..	Jr. Chemical Asstt., Laboratory
N. N. CHATTERJEE	..	..	"
S. P. GHATAK	..	..	Shift Foreman
M. M. SANYAL	..	..	"
J. V. CHALAM	..	..	"
S. K. BOSE	..	..	"

}	Testing Plant
---	---------------

The following have also served on the staff at different times :

B. KUBANEK	..	..	Fuel Technologist
M. C. MITRA	..	..	Chemist
M. K. HALDER	..	..	"
B. C. CHATTERJEE	..	..	Shift Foreman
J. DEY	..	..	"
A. K. MOITRA	..	..	"

## INTRODUCTION

THE MANUFACTURE OF COKE is of basic importance to the production of iron and steel, and, for this reason alone, it has a special claim to consideration in schemes for the industrial development of any country. It is well known that, although India has large supplies of iron ore of excellent quality, the reserves of good coking coal are limited; and it is, therefore, natural that the attention of scientists and technologists should have been given to the problem. As far back as 1927, Mr. N. Barraclough, now Chief Inspector of Mines, pointed to the likelihood of a shortage of coking coals in India, and estimated the life of the then known supplies at some 70 years — a salutary, but perhaps pessimistic, forecast.

Towards the end of 1940, a scheme for research on the blending and coking of coals was initiated by the Board of Scientific & Industrial Research, under the joint auspices of the Government of India and of the Tata Iron & Steel Co. Ltd., Jamshedpur. Each of the parties agreed to meet half of the expenditure to be incurred. With the generous assistance of Sir J. J. Ghandy, a Sub-Committee of officials of the Tata Iron & Steel Co. Ltd. was formed for the necessary administrative and technical control of the work which, it was agreed, should be carried out in the Company's Works, using existing facilities and purchasing apparatus as and when required. The Coal Blending and Coking Research Sub-Committee functions under the Fuel Research Committee of the Board of Scientific & Industrial Research, Government of India. The names of Committee and Staff Members are given on the preceding pages.

The chief object of the work was to investigate the blending of non-coking or feebly coking coals\* with good coking coals in order to manufacture from the blend sound metallurgical coke. The work was undertaken in the interests of the conservation of the resources of the best coking coal. The investigations were begun in April 1941 and have been carried out during the past 7 years. The present report deals with the results obtained up to March 1947.

It will be seen on perusing the report that the line of attack on the blending problem has been essentially trial and error. At the present stage of knowledge of the mechanism of coking, this is almost imperative since the process is understood only partially.

### THE COKING PROCESS

When coking coal in small pieces is heated in the absence of air, it usually begins to soften when a temperature of 300° to 350°C. has been reached, and, after softening, the mass becomes more fluid up to a temperature of about 400°C. The fluidity then decreases, and, before a temperature of 500°C. is reached, the mass becomes rigid. Different coals give different fluidities and at somewhat

---

\* Strictly speaking, a coking coal is one which gives strong, sound, commercial, metallurgical coke; a caking coal is simply one which cakes on laboratory carbonization tests and yields a coherent coke button. But the terms are, to some degree, interchangeable; "feebly caking coal", however, is perhaps preferable to the term "feebly coking coal", although the latter term is useful in implying the weakness and friability of the coke.

different temperatures, while non-coking coals do not become fluid at all. Those coals which, on a pure coal basis, yield 25 to 35 per cent of volatile matter (at 950°C.) give the maximum fluidity. This fluid or semi-fluid state is essential for the production of coke, and research in the present century indicates that it is brought about by the softening of the coal-bitumens which act as a dispersing medium for other portions of the coal substance, to form a plastic mass. In other words, the oily bituminous matter of the coal disperses or peptizes the micelles (organized molecular aggregates) of the coal substance, giving rise to a semi-fluid condition. The process is assisted by the liberation of volatile gases, which cannot immediately escape owing to the plastic nature of the mass and the sealing action of the oil film. A certain resistance to the escape of volatile gases is thus set up, and pressure is produced which causes the mass to swell. Swelling is essential if the mass is to be properly agglomerated, and a uniform cellular structure produced in the coke. It is the escape of the gases from the plastic mass that causes the cellular structure characteristic of all cokes. Beyond 500°C., gases continue to be evolved in quantity, but the mass has become rigid, and any change in structure is now one of shrinkage. Such shrinkage is desirable, but it must be controlled if a hard coke is desired.

In an actual coke oven, the coal in contact with the walls (temperature at the time of charging about 1100°C.) first softens and a plastic layer is formed alongside each wall of the oven. These plastic layers gradually move inwards as the carbonization proceeds, but it is several hours before they meet in the middle of the charge, although the width of the oven is only about 16 or 18 inches. Meanwhile, most of the hot gases and vapours pass outwards to the walls and are "cracked" to some degree in their passage through the already carbonized layers where they deposit carbon, usually in silvery coatings. The pressure exerted by most coals in the coking period is about 0.2 to 1 lb. per square inch, but with certain coals at the time when the plastic zones meet, a higher pressure — 3 to 5 lb. per square inch — is developed. This high pressure is immediately followed by a rapid fall due to the release of the gases previously held in the middle of the charge, enclosed by the zones. Subsequently, there is shrinkage as indicated above. Damage may have been done to the oven by the high pressure, even if the coke charge is easily expelled at the end of the usual coking period. Broadly speaking, it is low volatile coals which create dangerous pressure during coking. In many countries, e.g. U.S.A., such coals are coked only in admixture with high volatile coals, which gives incidentally an improved coke.

## QUALITY OF COKE

The chief desiderata in coke are purity, cohesion, size and uniform structure. These are governed mainly by the quality of the coal charged into the oven but also by the bulk density of the charge, the temperature, rate of heating and duration of carbonization, the size and shape of the oven, the degree of grinding and thoroughness of mixing of the charge, its sulphur and moisture content, and so forth. It is largely because of these variables that the laboratory, or even pilot-scale, tests for coking properties are not infallible, and require supplementing by actual tests in the oven in which the coal is to be carbonized. Nevertheless, laboratory and small-scale tests give valuable indications of the probable results of the full-scale operations, as will be seen from a perusal of the present report, where the pilot-scale work has been followed by full-scale tests on certain samples.

Regarding the special requirements of blast-furnace coke, uniformity is of great importance. Present variations in the physical and chemical properties of the coke supplied to the furnaces in India are, broadly speaking, too great to permit of high efficiency in the furnace operations. This is particularly true of

the ash content of the coke which varies with the ash content of the coal supplied to the ovens. Uniformity requirements may indeed necessitate extensive washing of the coal supplies in the future in order to produce a practically uniform ash content.

Resistance to shattering and to abrasibility of the coke is also lowered by irregular distribution of the foreign matter (ash); and, as strength and cohesion and size are to a degree interdependent and are of importance in the furnace operations, there would seem to be additional need for the adequate preparation of the coal before charging it into the coke ovens. Small coke and breeze are objectionable in a blast furnace inasmuch as they restrict the flow of air through the furnace. Coke serves not only as a fuel, giving the necessary heat and reducing atmosphere, but also as a spacing medium, permitting a well-distributed blast of air to flow through the furnace charge. Hence the necessity for tests which measure the strength and cohesion of the coke by measuring its resistance to shattering and to abrasibility.

#### CONCLUSIONS REGARDING BLENDING

It will be seen from the report that the upshot of the experiments as a whole is to show that, when mixed with good coking coal of caking index 15 or over, coals of a caking index of 13 or 14 may be used to the extent of 30 to 40 per cent; coals of caking index 8 to 12, to the extent of 20 to 30 per cent; and coals of caking index below 8, to the extent of 10 to 20 per cent. These conclusions are valuable: they indicate a definite extension of lease of life for the coking coal reserves of the country. But there are also other valuable results, such as the proof of the good coking properties of the Begonia seam and of the blends with Dishergarh coals.

Neglecting poor coking coals with caking index below 8, one will see that on an average 25 per cent of semi-coking coal (caking index 8-12) and 35 per cent of fair coking coal (caking index 13-14) can be used in blends with good coking coal. Why are these proportions so restricted? The reason is probably not far to seek. Indian coking coals contain a large amount of durain, which is basically a non-swelling and non-agglomerating constituent. It is true that certain durains will coke, especially if interleaved with "brights"; but, in the main, the essential coking constituents are found in the bright coal provided always that the coal is of the caking variety. When, however, a seam consists of alternating bands or layers of durain and "brights" (clarain), it may give a sound metallurgical coke, and this is the type of coal which predominates in the Jharia Coalfield.

Now, when the coal is entirely bright and of a strongly coking nature, it is usually possible to blend with it fairly large amounts of coal of a feebly caking nature (even containing durain in quantity) and still obtain an excellent coke from the mixture. If, however, durain is present in both seams in large amount, the coke is likely to be weak and unsatisfactory.

The Begonia and Dishergarh coals are essentially bright coals containing less durain than the coking coals of Jharia: they are by themselves fairly good coking coals; hence their satisfactory behaviour in blends is not surprising.

#### THE FUTURE

The First Report of the Fuel Research Committee on the Washability of Indian Coals has recently been published. It has given hope for a more extensive utilization of the Jharia coals for coking, and has shown that many of the seams



are amenable to improvement by washing and capable of yielding fractions suitable for coke manufacture. The same is true of the Bokaro coals.

The present Report on Coal-Blending extends still further the possibilities of using coals hitherto considered unserviceable for coke manufacture. There is now every indication that the rapid exhaustion of the coking coal supplies of the country (which a short while ago seemed likely) need not be envisaged. It is essential, however, to implement the findings of these reports, and also to prevent the utilization of good coking coal for non-coking purposes. Some action has already been taken in the latter respect in accordance with the recommendation of the 1946 Report of the Indian Coalfields Committee; but much remains to be done in the field of coal-washing (for different purposes) and of coal-blending.

Regarding the future work of the C.B. & C.R. Sub-Committee, several full-scale verification tests have yet to be carried out on coals already tested on a smaller scale. In addition, the programme of research comprises:

- (1) the study of the effect of variables, such as oven width, temperature, and rate of heating and grain size of coals;
- (2) assessing swelling and coking properties of coals in a more thorough and quantitative manner;
- (3) standardization of analytical and testing procedure by carrying out tests with coal of known swelling and coking properties procured from abroad;
- (4) investigation of special carbonization processes using blends of non-coking or poor-coking coals in admixture with coal-tar or pitch.

#### ACKNOWLEDGMENTS

For the good work already done acknowledgment is due to several persons. As pointed out earlier, the necessity for intensive research on the lines followed by the Coal Blending & Coking Research Committee was realized by Sir Jehangir Ghandy some years ago, and strongly supported by Sir Shanti Swarup Bhatnagar, F.R.S. The Tata Iron & Steel Co. Ltd. and the Board of Scientific & Industrial Research jointly agreed to finance the scheme of investigation. Our first acknowledgment is therefore due to the above persons and to the bodies they represent. Acknowledgment is due also to the management and staff of the Tata Iron & Steel Co. Ltd. for the practical assistance given in overcoming difficulties of equipment installation and the like. As the work of the Committee has extended over many years, there have naturally been some changes in personnel and constitution. To all, however, who have served at any period thanks are tendered for the results achieved. A special tribute is due to the able and energetic secretaries (Mr. M. P. Kanga, Mr. K. V. Ramchandram and Mr. N. N. Das Gupta) who from time to time have served the Committee so ably; and to Mr. E. T. Warren, not only for his services as a member of the Committee throughout the whole of its enquiries, but also for acting as Chairman and guiding the course of the investigations in the last few years. To Mr. A. Farquhar thanks are also tendered for the unflagging interest he has taken for many years, and to Mr. A. C. Bose, Superintendent of the Energy & Economy Department of the Company, and his Staff for generous and practical co-operation and for continued enthusiasm in the work.

J. W. WHITAKER

# CHAPTER I

## TESTING OF COAL & COKE

### 1. GENERAL PROCEDURE

Arrangements were made with the State Railways Coal Department for supplying the necessary samples for test purposes. Some samples were also received through the agency of Tata's Coal and Prospecting Departments.

*Standard Analytical Tests* were first carried out, including proximate analysis, determination of phosphorus and sulphur contents, caking index by Gray-Campredon method, swelling properties by Koppers and Nedelmann's apparatus, and fusion range of the ash. In addition, screen analysis, ultimate analysis, complete analysis of ash, determination of calorific value and of softening point of coal were also done in certain cases.

*Laboratory blending tests* were carried out as follows :

First, coals of possibly harmful swelling properties were blended with various other coking coals to study the effect of blending on the swelling characteristics.

Secondly, blends with normal coking coals, having a caking index of 15 (and above), were made with the following :

- (1) semi-coking coals of Gray-Campredon caking index — 8 to 12 ;
- (2) poor coking coals (caking index below 8) ; and
- (3) non-coking coals, yielding non-coherent coke buttons.

Among the good coking coals employed were :

- (a) the usual mixture used in Tata's coke ovens, which is a blend in varying proportions of a group of low and medium volatile coking coals, almost entirely from the Jharia field ;
- (b) low volatile, good coking coals from the Jharia Coalfield, such as Sijua 12 seam or 12, 13, 14 and 15 mixed seams, etc. ;
- (c) medium volatile, good coking coals such as Laikdih Deep, Laikdih seam, from the Raniganj field ;
- (d) high volatile, good-to-fair-coking coals, such as Murulidih, Mohuda Bottom seam, as well as some from the Raniganj field. A great variety of other coals from Jamadoba, Malkera, Choitodih, Digwadih, Bhatdee, Chanch and West Bokaro collieries were also used at the earlier stages.

Following the above laboratory work, semi-large-scale coking tests in specially designed electric (Swoboda) and/or gas-fired (Russell) pilot ovens (details of which are given later in this chapter) were carried out to check the laboratory results.

Finally, full-scale tests in Tata's Simon-Carves coke ovens were conducted for confirmation of the results of the semi-large-scale work.

The blends for semi-large-scale and large-scale tests were submitted to proximate analysis and to tests for bulk density of the charge. The resulting coke was submitted to: (1) proximate analysis; (2) screen analysis and (3) physical tests for Shatter Index, Breslau's abrasion, Haven's stability and porosity tests.

## 2. LABORATORY TESTS

(a) Moisture, ash, volatile matter, sulphur and phosphorus contents of coal and coke are determined according to British Standard Methods. (No. 1016—1942)

### (b) *Caking Index of Coal — (Agglutinating Value)*

The caking index is determined by Gray-Campredon method with modifications. Samples of coal pulverized to a size of 60 mesh are thoroughly mixed with various proportions of sand of size between 60 and 90 mesh, the total weight of the two being 5 gm.

The mixture (5 gm.) is taken in a standard silica crucible as used for the determination of volatile matter of coal and coke and heated at a temperature of 925°C. ( $\pm 25^\circ\text{C}$ .) for 7 minutes. The maximum ratio of sand to coal in a mixture, which yields a coke button just sufficiently strong to withstand a load of 500 gm. without crumbling (i.e. giving not more than 5 per cent of loose powder), gives the caking index of the coal.

For a matter of comparison of results, British Standard Method (No. 706—1936) is also followed.

### (c) *Screen Analysis of Coal*

All samples of coal except where it is supplied in the crushed state are initially crushed to a size of about 2" and then screened through the following square meshes (I.M.M.):

Over 2" ; 1" ;  $\frac{1}{2}$ " ;  $\frac{1}{4}$ " ;  $\frac{1}{8}$ " ; 30, 60 and below 60 mesh.

The percentages by weight, the ash contents and caking indices of the different fractions are next determined to study their respective properties.

### (d) *Bulk Density of Coal*

In order to compare the different coals on a common basis, all coals are initially crushed to a fineness of about 80 per cent through  $\frac{1}{8}$ " (as used for semi-large-scale coking tests). Approximately,  $1\frac{1}{2}$  cu. ft. of this coal is put into a metallic conical hopper, provided with a sliding shutter at the bottom. The slide is drawn out so as to give a full opening and the coal is allowed to run into a cubic foot wooden box— $12" \times 12" \times 12"$ . The distance of the edge of the box from the shutter is  $9\frac{1}{2}"$ . The excess of the coal is then struck off the box with a straight edge and the box and the coal are weighed.

It is a modification of the A.S.T.M. Method as introduced by the Koppers Company. (See FIG. 1.)

### (e) *Determination of Swelling Properties of Coal*

#### (i) BY KOPPERS APPARATUS (FIG. 2)

A charge of 80 gm. of coal up to 1 mm. size is taken in a steel cylinder fitted with a special base provided with perforations for the escape of gas. The coal is loaded with a piston and the cylinder is heated by means of a "Teclu" burner under a steady gas pressure of 35 mm. W.G. The swelling pressure developed on heating is transmitted to the piston which, in turn, pushes against a horizontal arm on which

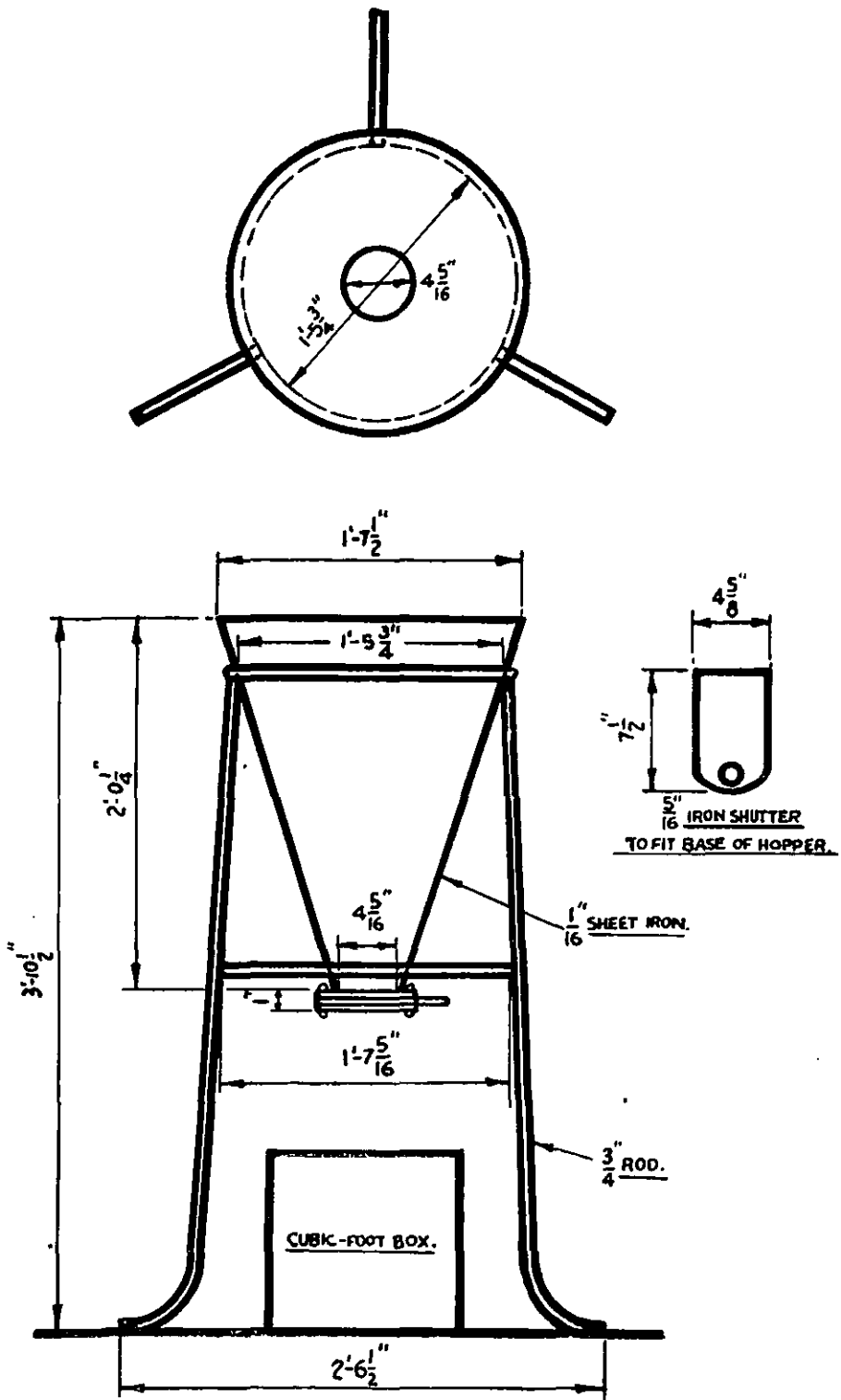

FIG. 1 — APPARATUS FOR DETERMINING CUBIC-FOOT WEIGHT OF COAL, AS USED BY THE KOPPERS CO.

are hung cylindrical weights. The movement of the piston is recorded by means of a pen on a recording drum. The curves traced out are compared with those obtained from standard coals and their swelling property studied. The results are reported under three different heads :

- (a) harmful ;
- (b) doubtful ; and
- (c) harmless.

The classification is obtained as follows :

- (1) Coals, the curves of which rise above the zero line and finish within 4 mm., are "*very harmful*".
- (2) (a) Coals, the curves of which rise above the zero line and finish within 8 mm., are "*harmful*".  
(b) Coals, the curves of which do not rise above the zero line but finish within 4 mm., are also "*harmful*".
- (3) (a) Coals, the curves of which rise above the zero line but finish below 8 mm., are "*doubtful*".  
(b) Coals, the curves of which do not rise above the zero line but finish within 8 mm., are also "*doubtful*".
- (4) Coals, the curves of which do not rise above the zero line and finish below 8 mm., are "*harmless*". (See FIG. 3 and FIGS. 14-20, pp. 29-32.)

(ii) BY NEDELMANN'S APPARATUS ( FIG. 4 )

This apparatus comprises of a special steel crucible with a perforated base. A charge of 120 gm. of coal of 1 to 2 mm. size is introduced into the cylinder which is placed inside a special furnace and heated by means of a powerful "Meker" burner. The pressure set up within the coals is transmitted through a piston to a lever arm pivoted between the plunger and a pressure manometer. The pressure is transferred to a cylinder closed by a rubber membrane and connected to the manometer. Thus, it registers the pressure set up by the coal and not the movement of the coal against a constant given pressure as in the case of Koppers apparatus.

In the case of dry coal (dried at 105°C.) having a bulk density of 51 lb. per cu. ft., a pressure of more than 14.22 lb./sq. in. developed during the tests is considered as "*dangerous*".

For a moist coal ( 10 per cent moisture ) having a bulk density of 52.2 lb. per cu. ft., a pressure of more than 7.11 lb./sq. in. is considered the danger limit. If the pressure is below these limits, the coal is nevertheless to be regarded as "*dangerous*" if the shrinkage is low ( less than 3 per cent ).

(f) *Determination of Softening or Melting Point of Coal* ( FIG. 5 )

The apparatus used works according to the penetrating system ( Baum-Bunte principle ).

A weighed quantity of the pulverized, air-dried coal is pressed into a briquette. It is placed on a small ring of an iron support enclosed by an iron tube over which is placed a vertical tube furnace. A pressure plunger with a thermo-element to indicate the temperature is let down through the iron tube and bears on the briquettes. The temperature rise of the furnace is properly regulated by means of resistance.

As the briquette softens, the plunger moves down and its movement is registered on a revolving drum. ( See FIG. 5.)

5

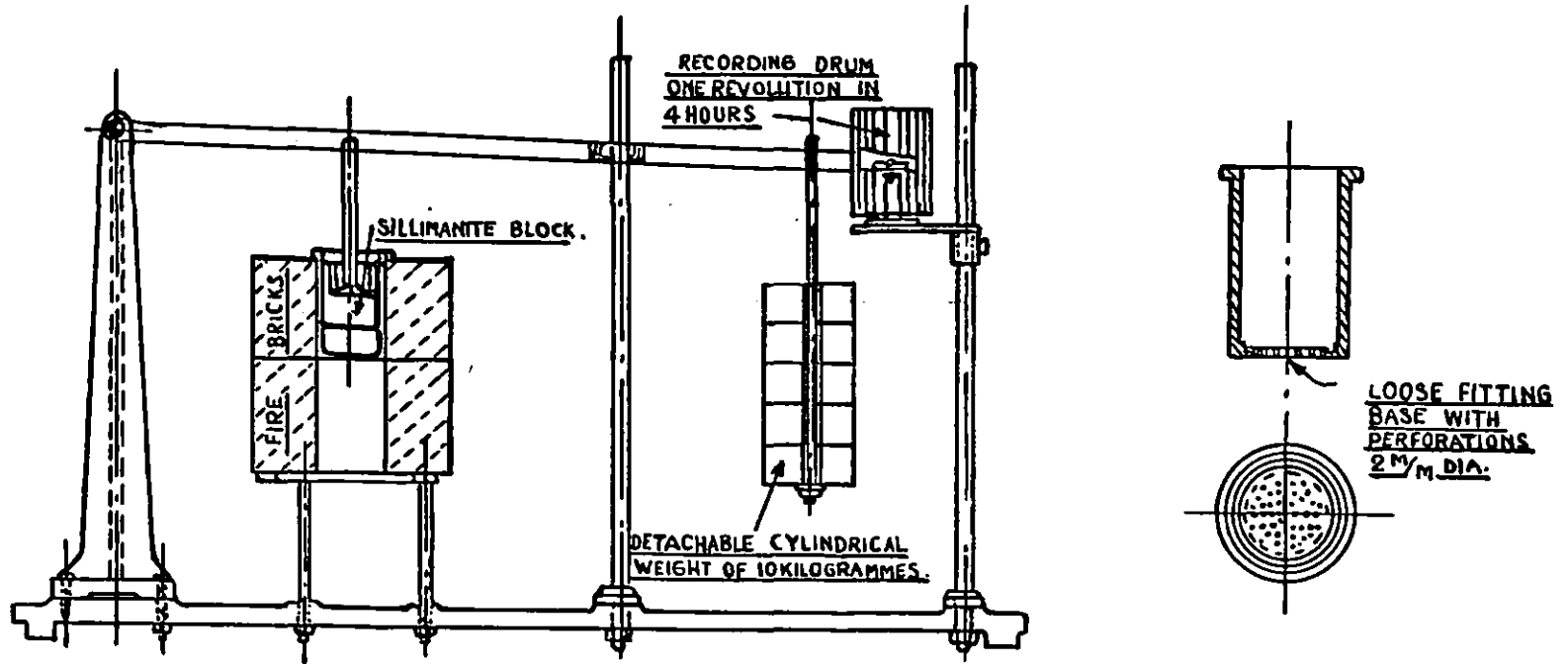
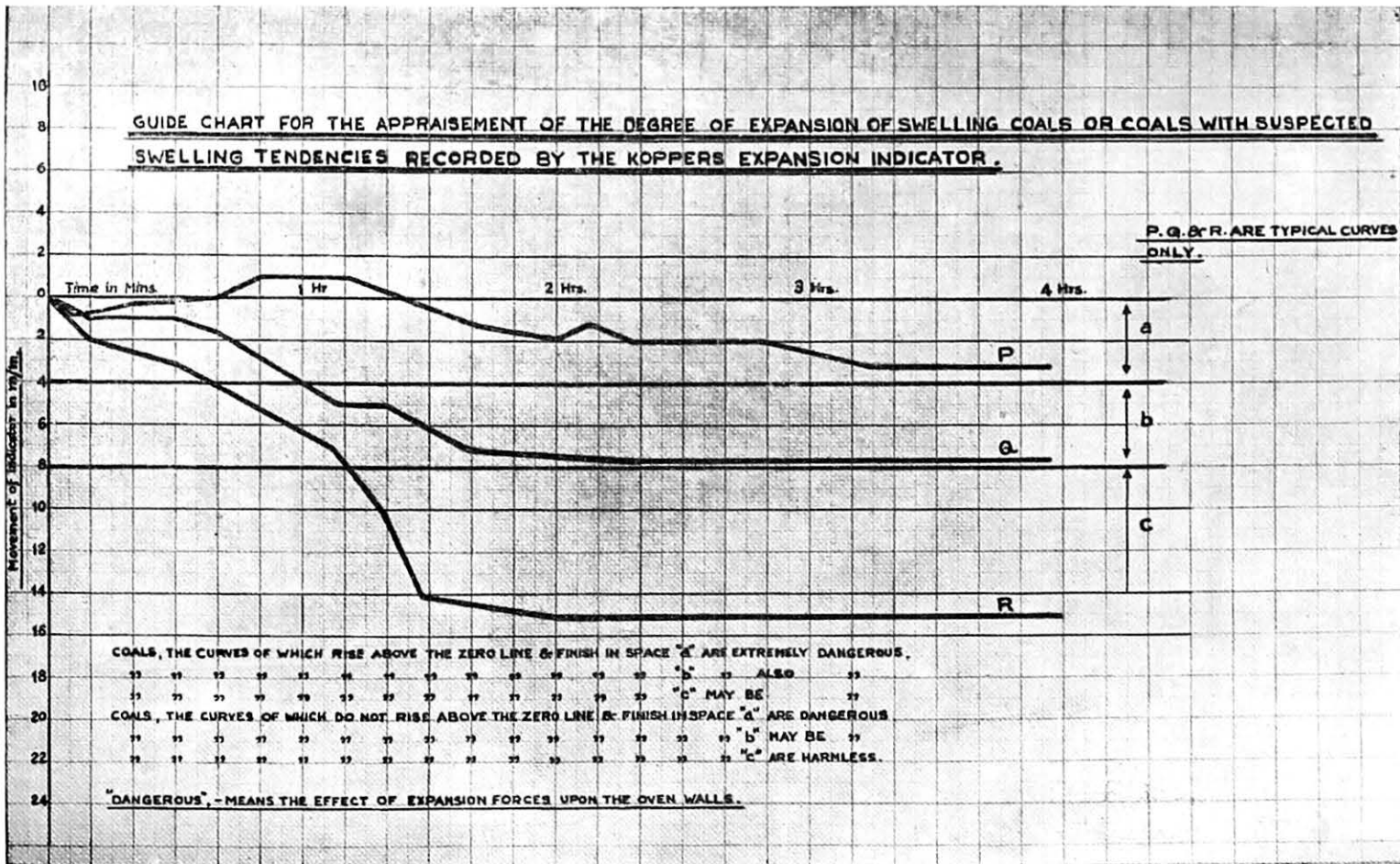
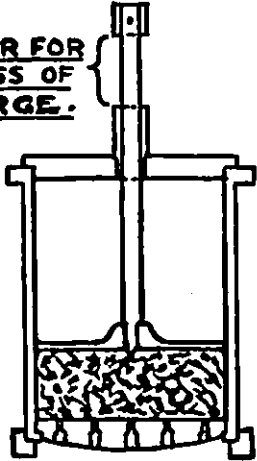

FIG. 2 — KOPPERS SWELLING-TEST APPARATUS



7

INDICATOR FOR  
THICKNESS OF  
CHARGE.



ENLARGED SECTION OF  
RETORT ON STAND WITH  
TAMPING DEVICE IN POSITION.

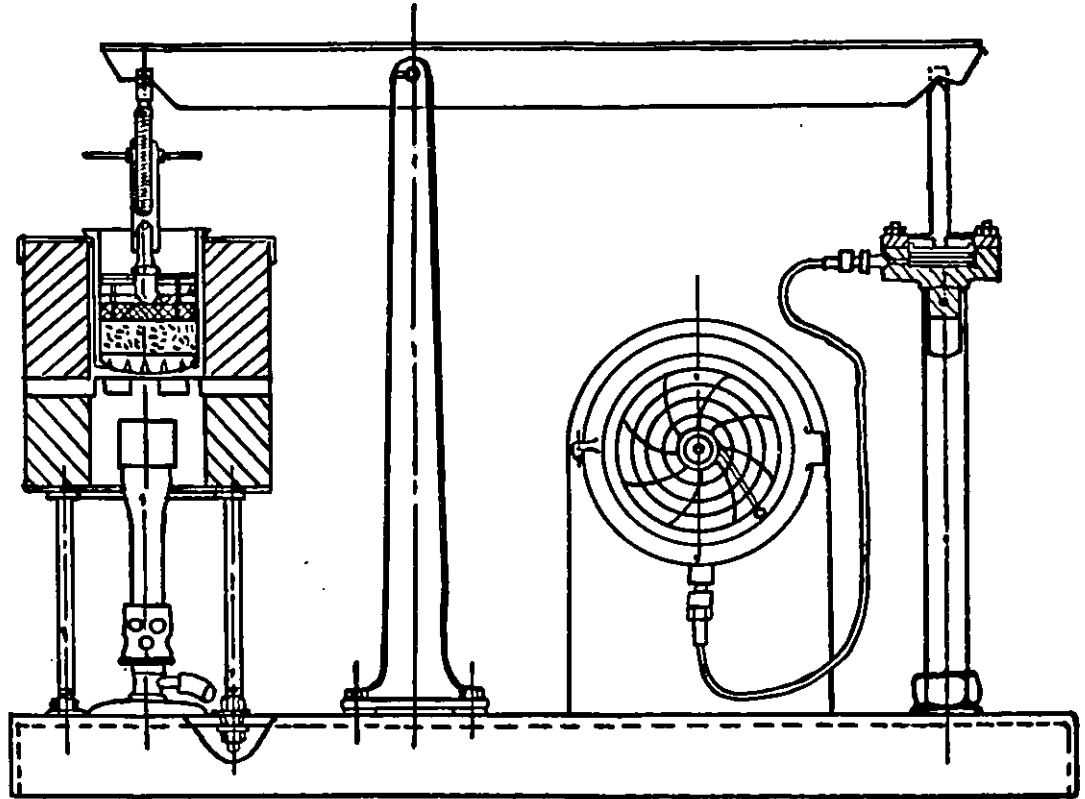

INCHES.

FIG. 4 — NEDELMANN'S APPARATUS FOR THE DETERMINATION OF SWELLING PRESSURE



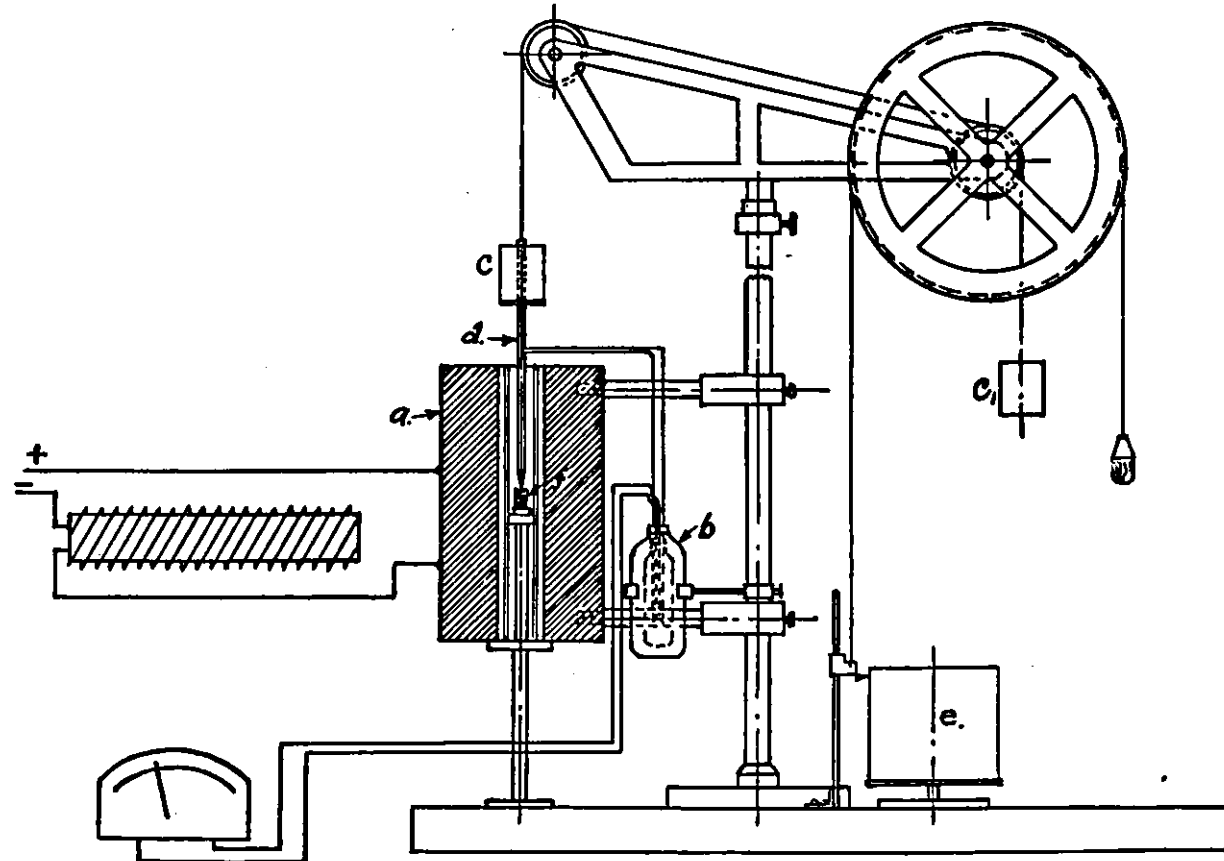

(a) Electric oven. (b) Thermostat. (c, c<sub>1</sub>) Counter weights. (d) Thermo couple — Pt., Pt.Rh.  
 (e) Register drum — Movement of the Thermo couple will show 4 times larger on the drum.  
 (f) Coal bricket — 13.3 mm. dia. × 19 mm. high, 3 gram coal.

FIG. 5 — APPARATUS FOR DETERMINING THE MELTING OR SOFTENING POINT OF COAL

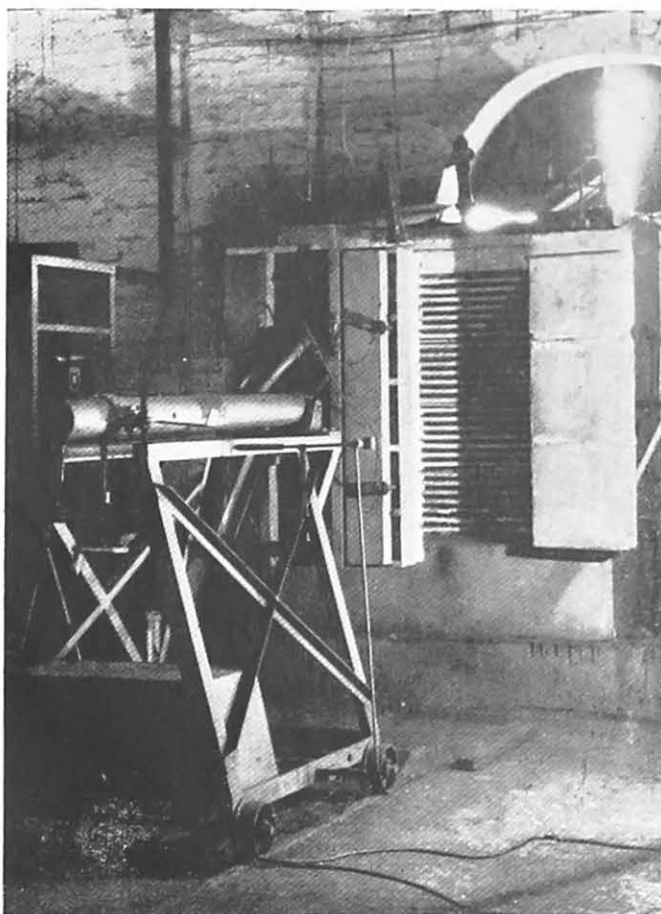

FIG. 6 — SWOBODA OVEN, WITH THE DOOR OPEN, SHOWING THE HEATING ELEMENTS ( DOOR AND BODY )

(g) *Determination of Fusion Range of Ash*

This is determined in a gas-fired muffle furnace in a reducing atmosphere. Small pyramids of ash are gradually raised in temperature and the particular temperatures, at which the tip of the cone indicates a tendency to bend down, touch the base and completely melt to a blob, are noted by an optical pyrometer.

(h) *Ultimate Analysis, Calorific Value of Coal & Complete Analysis of Ash*

These are also determined as per British Standard Method. (No. 1016—1942)

NOTE — Fine sieves used refer to I.M.M. standard. B.S.S. sieves are proposed to be used in future.

### 3. PILOT OR SEMI-LARGE-SCALE TESTS

(a) *Crushing & Blending*

All the coals required for the tests are crushed in a William's patent pulverizer and crusher, to a size, which, more or less, conforms to the size and gradation obtained in actual coke oven practice, i.e. 80 per cent through  $\frac{1}{8}$ ".

The requisite proportions of the crushed coal samples are subsequently thoroughly mixed in an electrically driven mixer pan.

(b) *Pilot Ovens for Semi-large-scale Tests*

(i) SWOBODA ELECTRIC OVEN (FIGS. 6 & 7)

The charge consisting of about 400 lb. is filled in a rectangular mild steel retort measuring 44" × 27" × 10". The purpose of the retort is to hold the sample tightly and to avoid damaging the heating coils. During carbonization, the coking chamber is heated by means of heating coils placed inside the wall at the rear and the front side (movable door) of the chamber. The maximum temperature is maintained around 850°C. during a coking period of 9 hours. The rate of heating is between 23° to 30°C. per hour and the carbonized mass is coked for a further period of 10 hours, at the maximum coking temperature.

After completion of the coking, i.e. after about 19 hours, the retort is removed and allowing it to cool in the atmosphere, the content (resulting coke) is taken out by breaking open the retort.

A maximum pressure of over 2.0 lb. per sq. in. recorded during the test indicates the coal to be of dangerous swelling characteristics.

(ii) RUSSELL GAS-FIRED OVEN (FIGS. 8 & 9)

Herein a charge of about 420 lb. of coal is carbonized at a temperature of around 900°C. (against a flue temperature of around 1100°C.) for a period of about 12 hours.

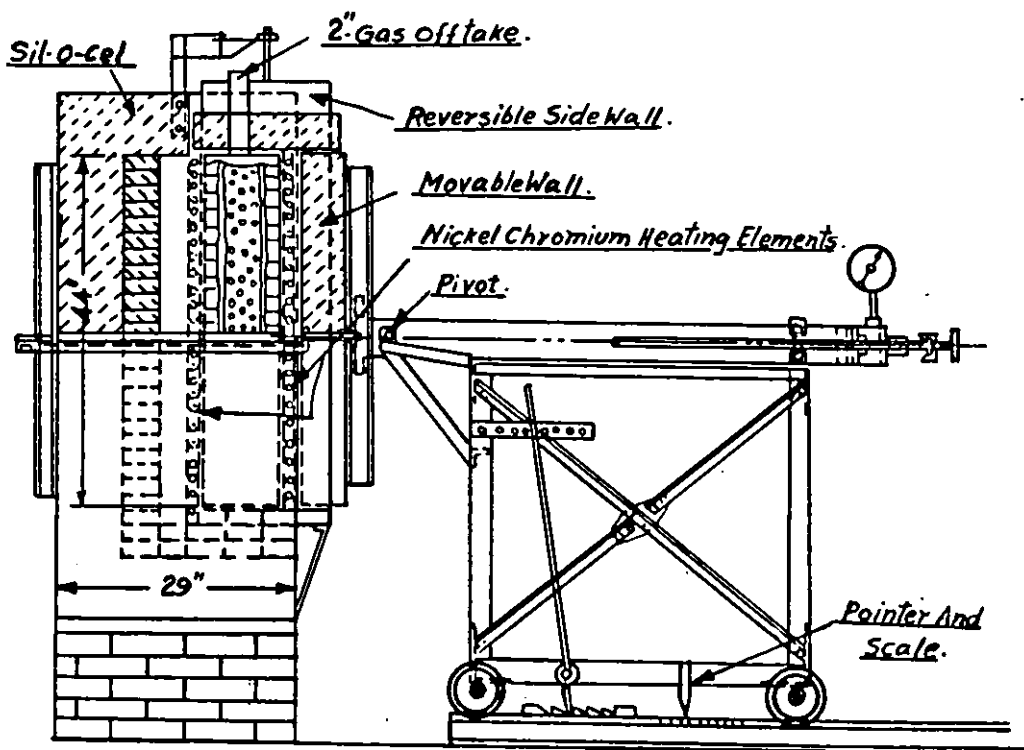

FIG. 7 — SWOBODA ELECTRIC OVEN

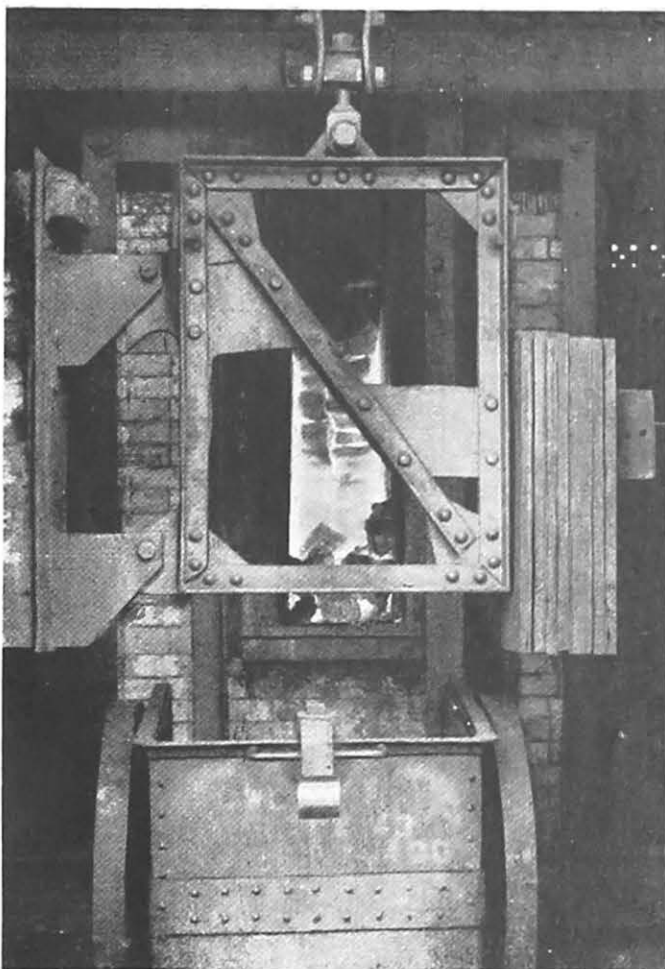

FIG. 8 — RUSSELL OVEN, WITH THE DOOR OPEN, SHOWING THE COKE MASS BEING RAKED

Unlike the Swoboda oven practice, the coke mass in this case is raked out from the chamber into a receiving trolley and manually quenched with water.

Both the ovens mentioned above were initially meant for measuring the swelling pressure developed during the carbonization of coals. But the Russell oven has now been considerably modified to serve the purpose of carrying out coking tests in a more efficient manner for assessing the quality of the resulting cokes and the Swoboda oven exclusively set apart for a measure of the swelling pressures of coals, for which it is better suited. (See also Figs. 10-13, pp. 20-24.)

### (c) *Physical Tests on Coke*

#### (i) SCREENING TESTS

The coke obtained from the semi-large-scale or large-scale tests is subjected to screening to get the yield of commercial Blast Furnace coke in different sizes as also those of Nut coke, Pearl coke and Coke-Breeze separately. All these are calculated both on the basis of the total coal charged and the total yield of coke.

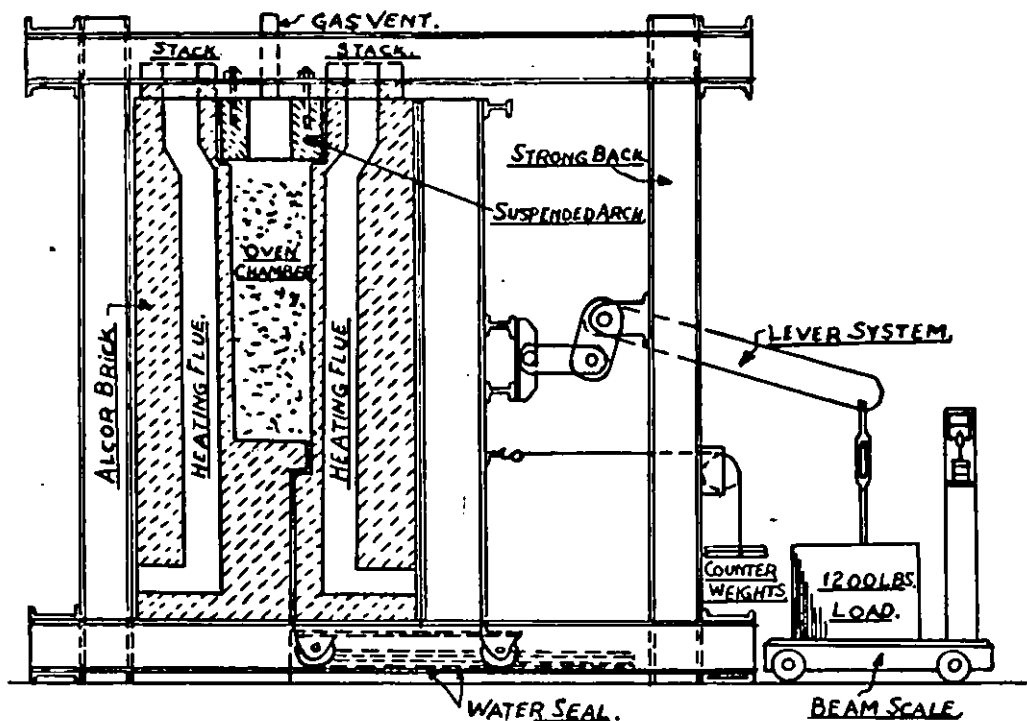

FIG. 9 — RUSSELL OVEN

- (a) Blast Furnace coke screened on 4", 3", 2" and 1½" sizes — (total on 1½" gives Blast Furnace coke).
- (b) Nut coke — total between 1½" and ¾" size.
- (c) Pearl coke — total between ¾" and ⅜" size.
- (d) Breeze — total through ⅜" size.

(ii) SHATTER INDEX TEST

50 lb. of coke, all over 2" size, are placed in a 20" cubical box the bottom of which consists of two hinged doors capable of being swung open so as to allow the coke to fall freely. The base of the box is supported at a height of 6 ft. above a steel plate, 48" × 38" × ½" (min.). The coke is dropped on to the plate four times, after which a size analysis of the pieces is carried out. Square mesh screens with 2", 1½", 1" and ¾" openings are used and the coke pieces are tried by hand to see if they would pass through the holes in any position. The shatter indices reported are the average values of the percentages retained on the 2" and 1½" screens.

(iii) BRESLAU'S ABRASION TEST (HARDNESS)

The hardness of coke is found by means of Breslau's abrasion test. 100 lb. of coke over 2" size are rotated for 4 minutes at 25 r.p.m. in a steel drum, 36" long × 36" dia. It is then screened on 100 mm., 80 mm., and 40 mm., round mesh screens, the sum total of the percentages of coke remaining on the 3 screens indicating the abrasion index. If this index is below 75, the coke would be considered soft; if over 75 and below 80, medium hard; if over 80 and below 85, hard; and if 85 or over, very hard.

#### (iv) HAVEN'S STABILITY TEST

In order to find out the stability, 22 lb. of coke of size between 2" and 3" are subjected to an hour's rotation in a steel drum (18"×36" dia.) at the rate of 25 r.p.m. The coke thus treated is then screened and the proportion (expressed in percentage) of coke remaining on 1" screen is taken to denote the stability.

#### (v) POROSITY

##### (a) Apparent Specific Gravity

Representative sample pieces of coke of a total weight of about 5 lb. are dried to constant weight on an electric hot plate.

Their weights in air having been obtained, they are kept immersed in boiling water for about half an hour, in order to saturate the pores with water. They are then taken out and the adhering water wiped off and the volume of the coke pieces measured by displacement of water in a special trough made for the purpose.

The apparent specific gravity is calculated by dividing the initial weight of the coke by the volume of the coke as determined above. (Prior to this, the specific gravity used to be determined by the Taylor's Balance or by mercury displacement method; but the above method has been found to give quicker and fairly concordant results allowing a larger bulk of sample to be taken for tests.)

##### (b) Real Specific Gravity

The real specific gravity is determined by an ordinary specific gravity bottle of 50 ml. capacity. (As per B.S.S. No. 1016—1942.)

##### (c) Percentage Porosity

$$100 \times \left( 1 - \frac{\text{App. Sp. Gravity}}{\text{Real Sp. Gravity}} \right) \text{ gives the porosity percentage.}$$

## 4. LARGE-SCALE TESTS

Full oven tests are carried out in one of the coke ovens of the Tatas.

### *Particulars of Ovens*

Simon-Carves Battery No. 3 (total of 55 ovens) are of "underjet" Compound Regenerative type, with twin-flue system of vertical heating, capable of being heated with coke oven and/or blast furnace gas.

Length of oven sole (cold)	..	44' 7"
Height of oven chamber (cold)	..	14' 6"
Width of oven chamber (hot)	..	425 mm. (Ramside)
Width of oven chamber (hot)	..	475 mm. (Coke side)

### *Heating Conditions During the Test Periods*

Net coal charged (wet)	..	20 tons (around)
Net carbonization period	..	Minimum 19 hr. 25 min. Maximum 22 hr. 20 min.
Mean flue temperature*	..	Minimum 1168°C. Max. 1250°C.
Mean oven wall temperature*	..	Minimum 991°C. Max. 1035°C.

---

\*Maintained according to the schedule of the carbonization period.

5. SPECIFICATION OF GOOD INDIAN METALLURGICAL COAL & COKE (LARGELY IN ACCORDANCE WITH THE VIEWS OF THE COALFIELDS' COMMITTEE'S REPORT — 1946)

A. COAL

(a) Swelling properties	..	..	Must be free from harmful swelling tendencies
(b) Phosphorus content	..	..	Less than 0.15 per cent (dry basis)
(c) Sulphur content	..	..	Less than 0.60 per cent ..
(d) Caking index (Gray-Campredon)	..	..	15 or above
(e) Ash	..	..	Less than 17 per cent (dry basis)
(f) Volatile matter	..	..	Around 26 per cent ..
(g) Fixed carbon	..	..	57 to 58 per cent ..

B. COKE

(a) Ash	..	..	22.5 per cent maximum (dry basis)
(b) Volatile matter	..	..	Less than 1.0 per cent ..
(c) Fixed carbon	..	..	75.0 per cent minimum ..
(d) Physical test :			
(i) Shatter index on 2"/1½"	..	..	82/92 per cent or over
(ii) Breslau's test (total on 40 mm.)	..	..	80 per cent or over
(iii) Haven's stability (total on 1")	..	..	50 per cent or over
(iv) Porosity	..	..	42 per cent or over

6. GRADING OF INDIAN COALS

(a) Ash

Seri. No.	As designated in this report	Range of ash content (dry basis)	
		Per cent	
1.	Very low ash	..	Up to 12
2.	Low ash	..	Above 12 and up to 15
3.	Medium ash	..	" 15 " 17
4.	Fairly high ash	..	" 17 " 20
5.	High ash	..	" 20 " 25
6.	Very high ash	..	" 25

(b) Volatile Matter

Seri. No.	As designated in this report	Range of volatile matter content (dry basis)	
		Per cent	
1.	Very low volatile matter	..	Less than 22
2.	Low volatile matter	..	Above 22 up to 27
3.	Medium volatile matter	..	" 27 " 32
4.	High volatile matter	..	" 32 " 40
5.	Very high volatile matter	..	" 40

(c) *Classification According to Notification No. 205 D/31-1-1945 by the Government of India, Dept. of Supplies*

(i) COAL FROM SEAMS OF THE RANIGANJ SERIES

Grade	Ash + Moisture Per cent
Sel. A .. ..	Not over 17.5
Sel. B .. ..	17.5 to 19.0
Gr. I .. ..	19.0 to 24.0

(ii) COAL FROM SEAMS OTHER THAN THE RANIGANJ SERIES\*

Grade	Ash content Per cent
Sel. A .. ..	Less than 15
Sel. B .. ..	Between 15 and 17
Gr. I .. ..	" 17 " 20
Gr. II .. ..	" 20 " 24
Gr. III-A .. ..	" 24 " 28
Gr. III-B .. ..	" 28 " 35

7. COKING PROPERTIES OF COALS

- (i) Coals having a caking index (Gray-Campredon) 15 and above are designated in this report as .. good coking coals.
- (ii) Coals with a C.I. between 13 and 14 .. fair coking coals.
- (iii) Coals with a C.I. between 8 and 12 .. semi-coking coals.
- (iv) Coals with a C.I. below 8 .. poor coking coals.
- (v) Coals, which do not cake at all, but yield only a pulverulent residue from volatile matter tests, are designated as *non-coking coals*.

NOTE — The appearance of typical Indian cokes is seen in pages 16 and 17, plates 1-4.

The results of Russell Oven tests are indicated graphically in Figs. 10-13, pp. 18, 19, 20 and 21.

---

\* The moisture should not exceed 2 per cent.





PLATE 1 -- NORMAL COKE FROM MIXED CHARGING COAL AS USED IN TATA'S COKE OVENS

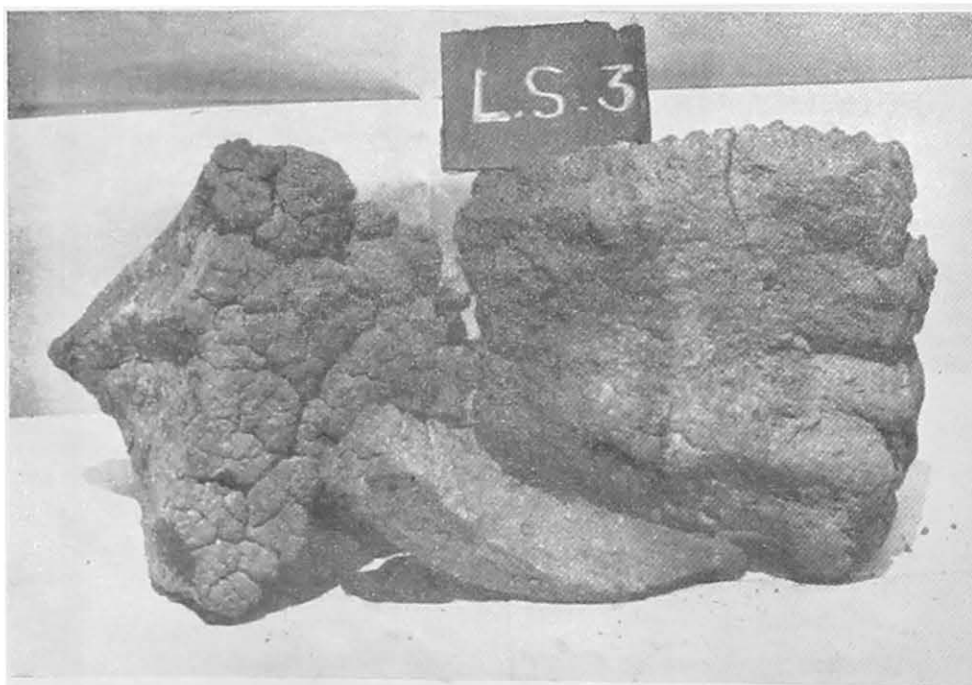

PLATE 2 -- COKE FROM BLEND : SEETALPUR SANCTORIA SEAM ( RANIGANJ ) -- 30 PER CENT  
MIXED CHARGING COAL FROM TATA'S COKE OVENS -- 70 PER CENT

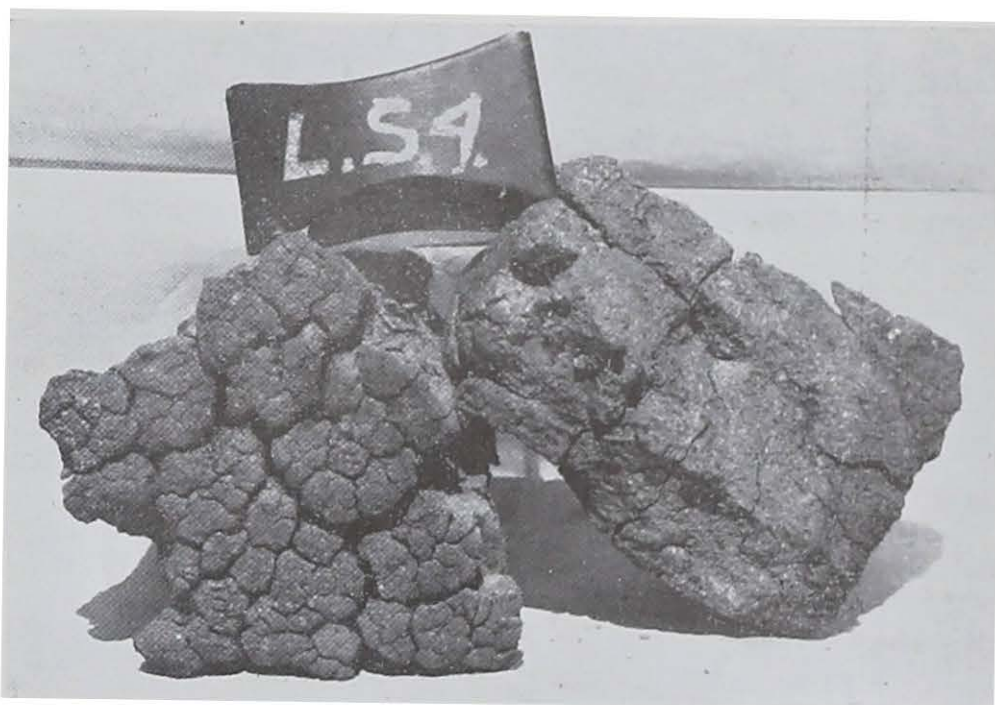

PLATE 3 — COKE FROM BLEND : BEGONIA, BEGONIA SEAM ( RANIGANJ ) — 30 PER CENT  
MIXED CHARGING COAL FROM TATA S COKE OVENS — 70 PER CENT

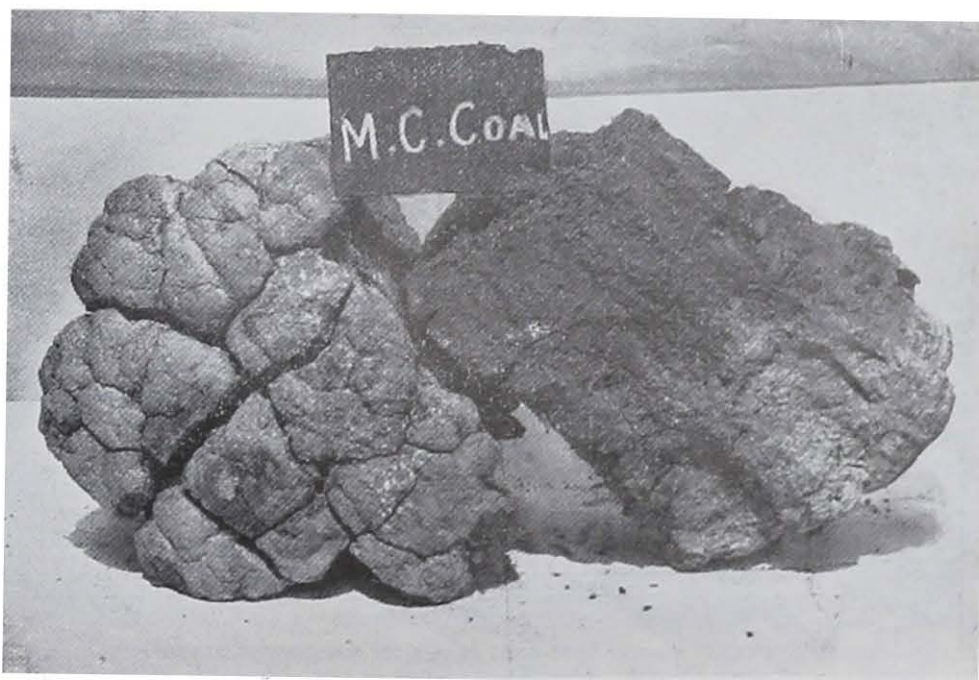

PLATE 4 — COKE FROM BLEND AS ABOVE SHOWING THE COKE PIECES IN A HEAP

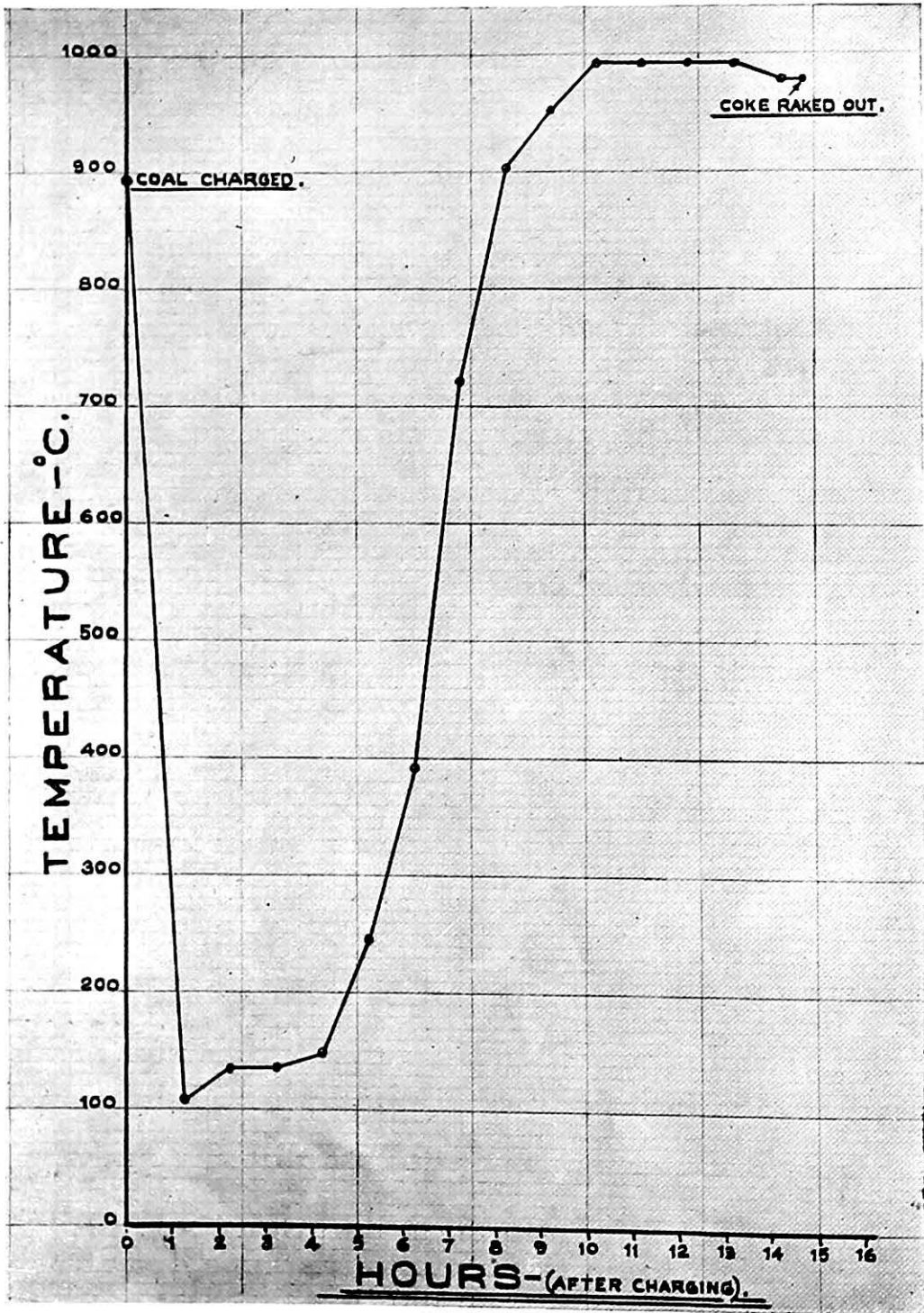

FIG. 10 — RUSSELL OVEN. COKING TEST-EXPT. NO.-R-34. CHARGE — MIXED CHARGING COAL FROM T.I.S.CO. COKE OVENS. TIME TEMPERATURE CURVE — SHOWING COKE MASS TEMPERATURE AT CENTRE OF OVEN

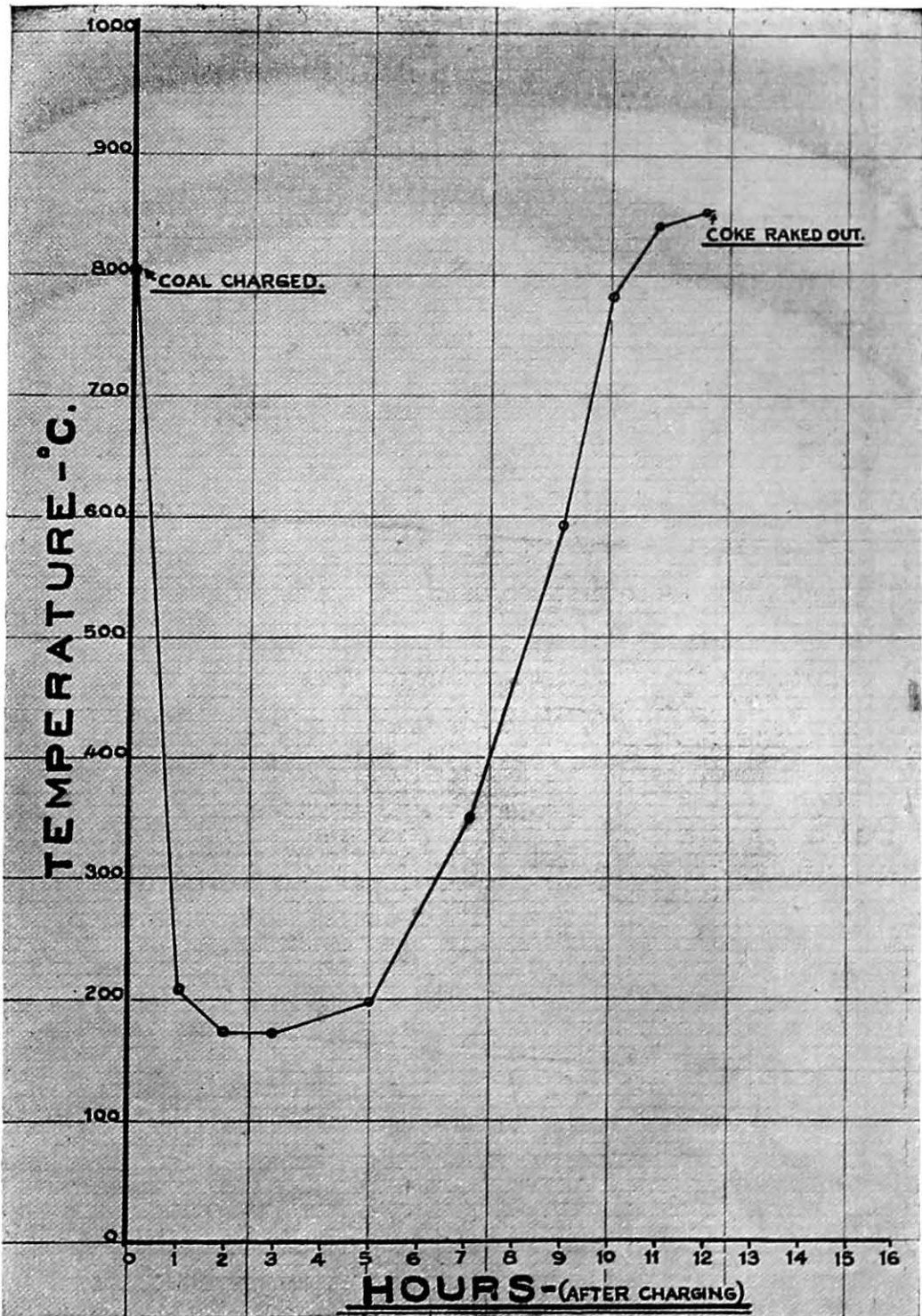

FIG. 11 — RUSSELL OVEN. COKING TEST-EXPT. NO.-R-38. CHARGE — MIXED CHARGING COAL FROM T.I.S.CO. COKE OVENS. TIME TEMPERATURE CURVE — SHOWING COKE TEMPERATURE AT CENTRE OF OVEN

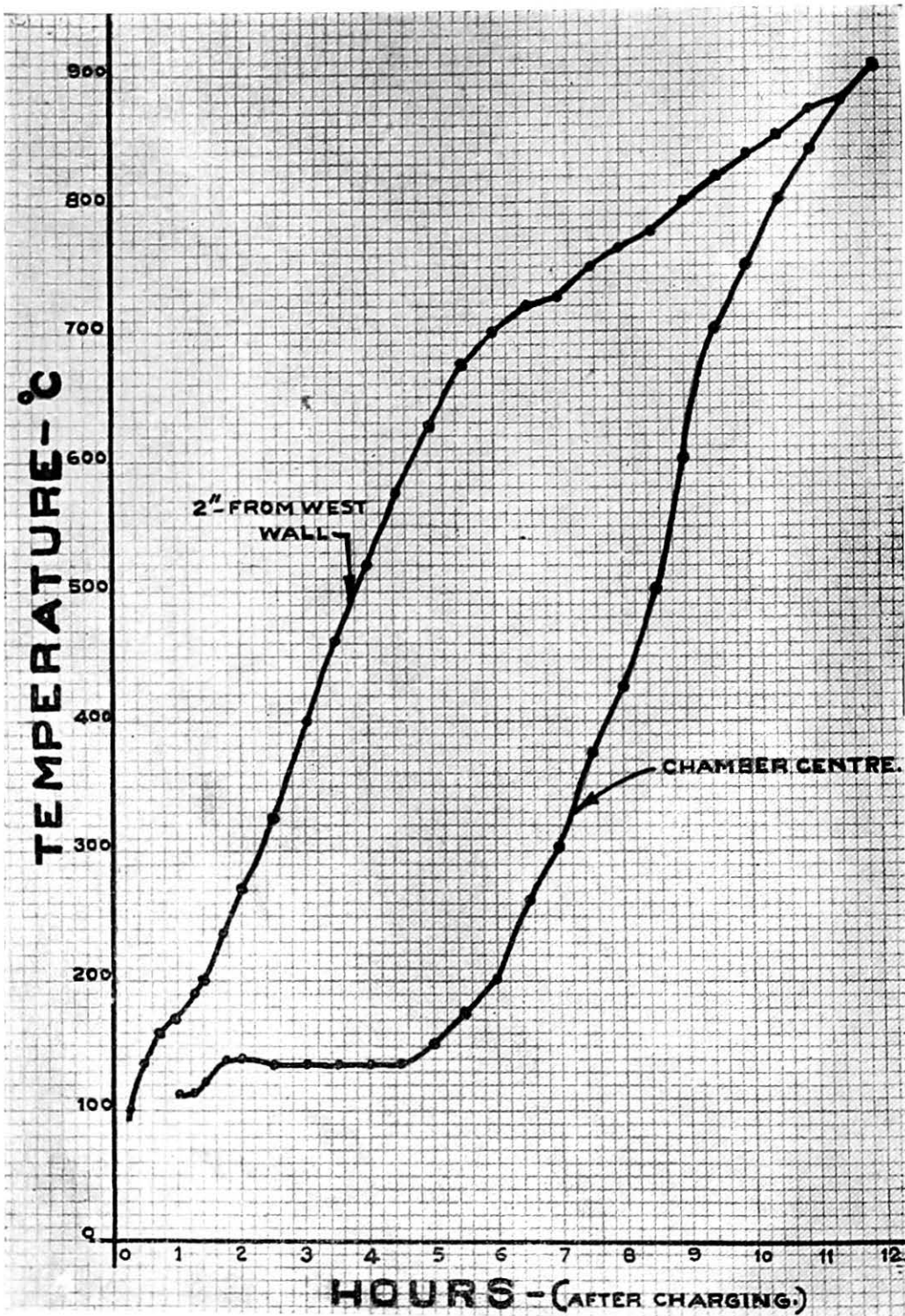

FIG. 12 — RUSSELL OVEN. COKING TEST-EXPT. NO.-R-81. CHARGE — GHUSICK 25 PER CENT AND LAIKDIH 75 PER CENT. TIME TEMPERATURE CURVE — SHOWING COKE MASS TEMPERATURE AT CENTRE OF OVEN AND AT 2" FROM WEST WALL

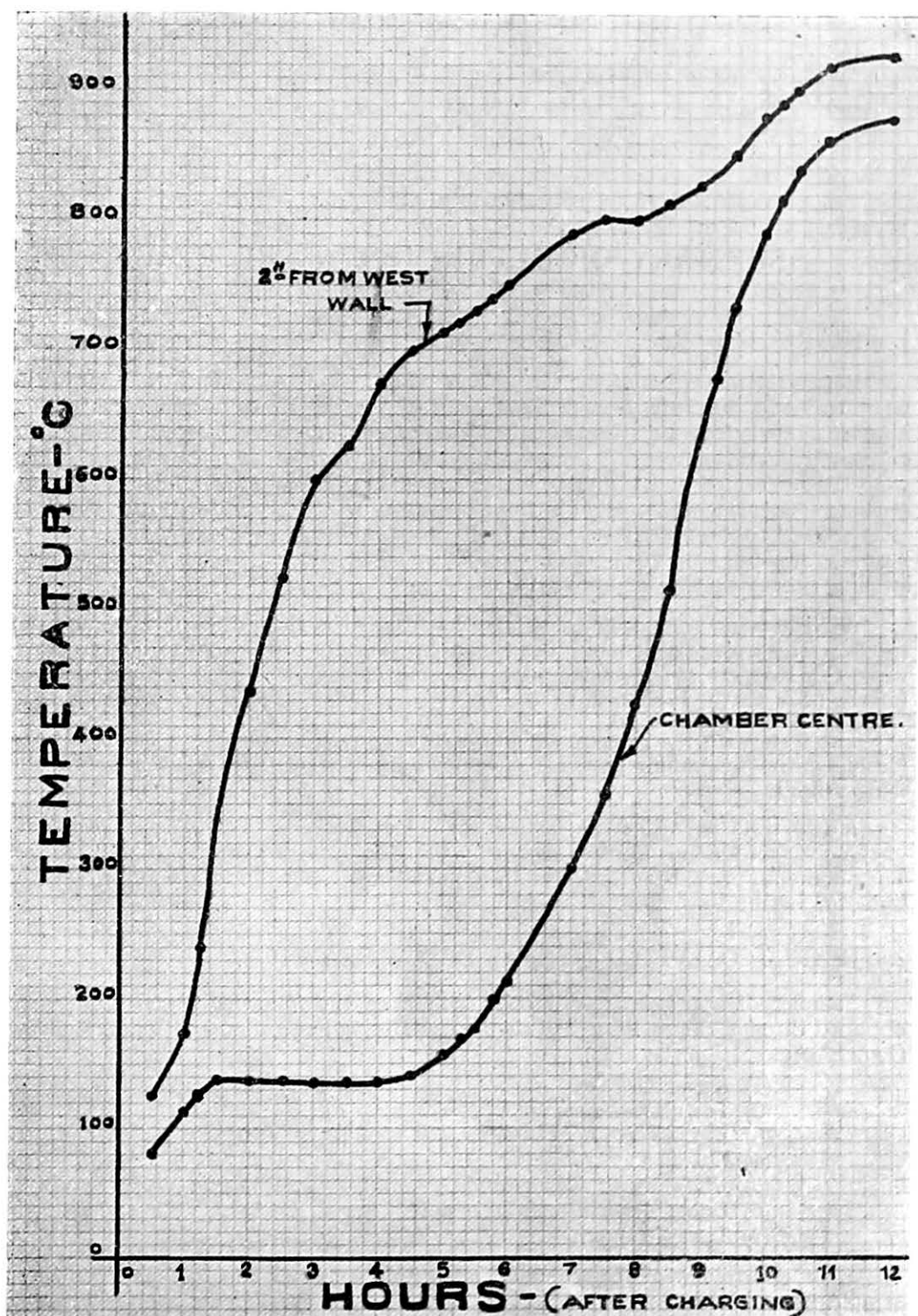

FIG. 13 — RUSSELL OVEN. COKING TEST-EXPT. NO.-R-84. CHARGE — NEW KENDA 20 PER CENT AND SIJUA MIXED 80 PER CENT. TIME TEMPERATURE CURVE — SHOWING COKE MASS TEMPERATURE AT CENTRE OF OVEN AND AT 2" FROM WEST WALL

## CHAPTER II

### SUMMARY OF EXPERIMENTAL RESULTS

#### 1. JHARIA COALS — SWELLING TESTS

Before the formation of the C.B. & C.R. Sub-Committee, tests carried out in the laboratories of the Tata Iron & Steel Co. Ltd., in the Koppers apparatus with a number of coals from the Jharia Coalfield indicated that these coals were of harmful or possibly harmful swelling properties. Thirty-five fresh samples of these seams were later obtained and tested. Of these, only 11 proved to have possibly harmful swelling tendencies when tested in the Koppers apparatus. Subsequent laboratory tests showed that an admixture of 5 to 10 per cent of other good coking coals of harmless swelling properties (or of coke-breeze) was sufficient to off-set the harmful swelling properties of the above 11 coals.

A Nedelmann's apparatus was later constructed in the T.I.S.Co. shops and put to use. This apparatus enables the expansive pressure of the coal to be measured, while the Koppers apparatus registers the movement of the coal against a given force. (See CHAP. I, SEC. 2.)

The tests with the Nedelmann's apparatus proved all the above 35 coals to be harmless, the maximum pressure developed in each case being well below the danger limit.

A few tests were likewise carried out in the Swoboda electric oven with some of the coals and blends already shown by the laboratory apparatus to be harmless. The maximum pressure recorded in all the cases was lower than the specified danger limit for harmful swelling.

#### 2. JHARIA COALFIELD — SEAMS BELOW SEAM 10

Samples of approximately 1 cwt. each from the following seven areas were obtained through the assistance of the Indian Mining Federation and Indian Colliery Owners' Association :

(1) Kusunda Area	..	..	21 samples
(2) Teetulumuri Area	..	..	21 "
(3) Katrasgarh Area	..	..	20 "
(4) Nawagarh Area	..	..	25 "
(5) Nudkhurkee Karmatand Area	..	..	14 "
(6) Dobari Jharia and Dhanswar	..	..	18 "
(7) Tisra-Jenagora	..	..	20 "

A general review of the results of laboratory analyses and tests done on these samples revealed that :

- (i) the majority of the 139 samples obtained were either semi or poor coking with caking indices between 6 and 12, the ash content of the coal ranging from 20 to 30 per cent ;

- (ii) only 8 samples, mostly from the Kusunda Area, gave good to fair coke with caking indices between 13 and 17;
- (iii) there were 20 cases where the ash content exceeded 30 per cent;
- (iv) all the samples were of low volatile matter content, varying between 16 and 22 per cent ( i.e. 20 to 30 per cent ) on a pure coal basis;
- (v) the sulphur and phosphorus contents were well below the limits specified for metallurgical coke, except in five samples where the sulphur exceeded 0.6 per cent and in 15 per cent cases where the phosphorus was above 0.15 per cent.

Laboratory blending tests were carried out with all the samples having an ash content below 25 per cent and with some of the samples whose ash content was between 25 and 30 per cent. Those having an ash content exceeding 30 per cent were excluded from blending tests.

The conclusions for Jharia field coals, below 10 seam, are :

- (i) semi-coking coals with comparatively low ash content ( below 20 per cent ) could possibly be used with 40 to 50 per cent of any of the reasonably good coking coals of low, medium, or high volatile groups;
- (ii) semi-coking or poor coking coals with higher ash contents, between 20 and 25 per cent, could probably be used to the extent of
  - (a) 30 to 40 per cent with low volatile coking coals and
  - (b) 20 to 30 per cent with medium or high volatile coking coals;
- (iii) semi-coking or poor coking coals with still higher ash contents, i.e. above 25 per cent, could be utilized to a maximum extent of 20 per cent with other good coking coals.

### 3. COALS FROM THE RANIGANJ COALFIELD

In all 67 samples were received in wagon loads from various seams comprising Dishergarh, Poniati, Kajora, Ghusick, Begonia, Sanctoria, etc. Most of the coals were either semi or poor coking with fairly low ash ( 11-15 per cent ) and high volatile matter ( 35-40 per cent ). Exceptions were the West Laikdih ( Kharbari seam ), Sanctoria ( Hatnal seam ), West Jotedhemo ( Bombahal seam ) and Korabad ( Kasta seam ) coals, whose ash content exceeded 20 per cent in each case. The volatile matter content of Begonia ( Begonia seam ), Badjna ( Badjna seam ) and West Laikdih ( Kasta seam ) were 29 per cent, 23 per cent and 27 per cent respectively. The moisture contents of Kajora, Samla, Bogra, Bombahal, Kenda, Chowkidanga and Taltore seam coals were above 5 per cent but below 10 per cent.

Results of laboratory blending tests ( followed by semi-large-scale or large-scale coking tests in certain cases ) indicated that :

- (a) a maximum of 30 per cent of the semi-coking coal is usable in blends with other good coking coals, although some of the better grade coals ( fair coking and semi-coking type ) of the Dishergarh seam yielded more encouraging results from laboratory tests;
- (b) the maximum proportion of the poor or non-coking types that could be utilized was not higher than 10 to 20 per cent;
- (c) semi-large-scale tests ( followed by full oven tests ) with (i) 100 per cent of Begonia seam and (ii) 30 per cent of Sanctoria seam ( Seetalpur ) coal blended with 70 per cent of mixed charging coal from Tata's coke ovens, yielded hard metallurgical cokes.



#### 4. COALS FROM THE CENTRAL PROVINCES (INCLUDING KOREA & REWA STATES)

Altogether 24 samples (9 wagon loads and the rest in small lots) were received, of which only 4 were semi-coking with caking indices between 8 and 12, the others being practically non-coking.

The coals contained from 17 to 25 per cent ash, and from 29 to 38 per cent volatile matter. The moisture figures were high, the highest (16 per cent) being recorded in the case of Rajur coal. The semi-coking coal from the Rakhikol colliery and the two non-coking coals from Rajur and Sasti collieries had sulphur contents of about 1.7 per cent, 1.0 per cent and 1.1 per cent respectively.

Blending experiments showed that maxima of 25 to 30 per cent of the semi-coking type and 10 to 15 per cent of the non-coking type coals were usable with good coking coals.

#### 5. COALS FROM THE SOUTH KARANPURA COALFIELD

A wagon load of Sirka Colliery coal, scheduled for consumption in the Steel Company's boilers, was taken for coking tests. The average analysis of different samples (slack, steam, or run-of-mine sizes) revealed the coal to be of medium ash and high volatile matter content, belonging to the poor coking class.

Laboratory blending tests, supplemented by semi-large-scale tests, showed the possibility of utilizing 10 to 20 per cent of this coal in admixture with others of good coking characteristics.

#### 6. COALS FROM HYDERABAD (DECCAN)

Two samples of coals from the Singareni Colliery Company, Tandur, and Kothagudium "A" Grade were received in lots of 2 tons each. Both were non-coking and of low ash and high volatile matter content. A high fusion range (1425°-1465°C.) of ash was a good feature of this coal. The moisture contents were 10.2 and 5.4 per cent respectively.

Experiments indicated that not more than 10 per cent of these coals could be used in blends with Tata's normal coke-oven mixture or with the low volatile coals from the Jharia field.

#### 7. COALS FROM MADRAS

A small borehole sample of brown, lignitic coal from a newly discovered mine was received for test purposes. On analysis it yielded: moisture 12.5 per cent; ash 5.0 per cent and volatile matter 49.5 per cent.

The laboratory tests showed that about 10 per cent of the coal could be used in blends with high volatile coking coal, while any blends with low volatile coking coals failed to give satisfactory results.

#### 8. COALS FROM ASSAM

Small lots of samples of about 160 lb. each were received from:

- (1) Namdang (Baragolai),
- (2) Dilli and
- (3) Cherrapunji.

The ash content of the first two was 5.54 per cent and 7.59 per cent respectively, while that of the third was 18.54 per cent; the volatile matter was between

39.0 and 44.0 per cent. The Dilli coal was non-coking ; the other two were fair coking. The moisture content of Dilli coal was 4.5 per cent and that of the other two was around 2 per cent. As usual with Assam coals, the sulphur content was very high in all cases, being from 4 to 7 per cent.

## 9. COALS FROM AUSTRALIA

Five samples were received, each of about 400 lb. They were good coking coals from the Southern District of New South Wales, from the collieries at

- (1) Wongawilli ( cleaned ),
- (2) Bulli ( large and smalls ) and
- (3) Mt. Kembla ( large and smalls ).

These coals were all of low ash content ( 10 to 13 per cent ) and low volatile matter ( around 26 per cent ) and thus comparable with the best grades of Jharia coking coals. Excepting Wongawilli, which gave a doubtful swelling curve when tested in the Koppers apparatus ( not corroborated from Nedelmann's test ), they proved to have harmless swelling properties. The coke obtained from semi-large-scale carbonization tests satisfied the requirements of good metallurgical cokes.

## 10. SPECIAL TESTS

### (a) *Sample of Natural Coke ( Jhama ) from the Jharia Coalfield*

A wagon-load sample of natural coke from Khas-Jharia Colliery was put to the usual tests for metallurgical coke. Its ash content varied widely for different samples from the same wagon ( 17.53 to 20.54 per cent ) ; but the volatile matter was fairly constant, being about 18 per cent.

The physical tests yielded poor results in all respects, compared with those of metallurgical coke.

### (b) *Experiments on the Production of Low Ash Coke*

In order to study the possibility of making low ash coke of the required physical and chemical properties for recarburizing purposes in the Steel Works and for use in Tata Chemicals at Mithapur, a few semi-large-scale tests were carried out with various blends of : (i) Laikdih deep, ( Laikdih seam ) ; (ii) Bararee 14, 14-A and 15 seam ; (iii) Sijua 12 and 14 seam ; (iv) Kustore 15 seam ; and (v) Sripur ( Poniaty seam ) coals.

A mixture of Bararee 14, 14-A and 15 seam and Laikdih deep in the proportion of 50 : 50 yielded the best results.

### (c) *Carbonization Tests with Blends of Coal & Coke-breeze*

Altogether 18 carbonization tests were carried out with blends of mixed charging coals from Tata's coke ovens and high temperature coke-breeze from the same source. It was apparent that finely ground coke-breeze ( about 80 per cent through  $\frac{1}{8}$ " mesh ) to the extent of 2 per cent could be used without any deleterious effect on the coke produced ; but this figure of 2 per cent could not be exceeded.

## CHAPTER III

### DISCUSSIONS & CONCLUSIONS

#### 1. CAKING INDEX (AGGLUTINATING VALUE)

A careful differentiation between the terms "coking" and "caking" may be made. A caking coal generally means one which gives a coke button in the laboratory volatile matter test. A coking coal is one which, on commercial carbonization, yields strong metallurgical coke.

The caking index or agglutinating value is determined by tests involving the capacity of a coal to yield a coherent mass when carbonized in admixture with some inert material — (sand, in the Gray-Campredon method as followed in the C.B. & C.R. Laboratory): It gives a measure of the "caking power" rather than of the "coking power" of a coal, an inexact term but useful in conveying the impression of strength and cohesion in the coke.

Broadly speaking, the caking index is a good measure of coking power, but a perfect correlation between such caking index values for coals and the physical properties of the resulting cokes has not been established.

Based on experience gained from the steel works practice, the interpretation of the laboratory test results has been made on the assumption that a minimum caking index value of 13 to 15 for coals or blends indicates suitability for producing satisfactory cokes.

#### 2. MOISTURE CONTENT OF COALS

The tests of coals from the Raniganj area, the Central Provinces, Hyderabad (Deccan) and Assam show that high natural moisture is associated with non-coking or poor coking properties. In other words, the lower the moisture, the better the coking power.

#### 3. SWELLING PROPERTIES OF COALS

Coals reported as harmful by the Koppers apparatus have often proved to be harmless in the Nedelmann's apparatus or the Swoboda oven. With some reservation, it may be concluded that there is hardly any coal in India, which may have to be classed in the category of harmful swelling coals. Furthermore, the addition of 5 to 10 per cent of other good coking coals of harmless swelling properties has been found to off-set the swelling tendencies of *possibly* dangerous coals as indicated by Koppers apparatus. Hence, the danger of damage to oven walls by using Indian coals seems remote: no individual coal by itself is likely to be used in large-scale commercial carbonization.

#### 4. BLENDING RESULTS

The maximum proportion of any weakly coking coal that can be utilized in blends to produce metallurgical coke is essentially dependent upon its caking power as well as upon the coking properties of the coal it is blended with. Ash content also seems to have an important bearing in lowering coke strength.

Although caking index values determined in the laboratory serve only as a rough guide for assessing the actual coking or coke-making properties, the laboratory tests have demonstrated the blending possibility of low grade coals to the following extent in admixture with good coking coals :

- (i) 30 to 40 per cent for fair coking coals ;
- (ii) 20 to 30 per cent for semi-coking coals ; and
- (iii) 10 to 20 per cent for poor or non-coking coals.

The volatile matter content of the blend should, however, be kept sufficiently low in order that after carbonization

- (i) the ash content in the resulting coke shall be low ;
- (ii) the fixed carbon in the coke shall be sufficiently high ; and
- (iii) excessive shrinkage shall be avoided.

In general, the higher the proportion of non-coking or feebly coking coals added to a good coking coal, the weaker the coke produced both in small-scale and in full-scale tests.

#### 5. JHARIA COALFIELD — SEAMS BELOW SEAM 10

The high ash content of some of these good to fair coking coals precludes their immediate utilization for coke manufacture unless they are used in blends with other good coking coals of sufficiently low ash. These high ash good coking coals, therefore, along with several others of the semi-coking type, *should be washed* to reduce their ash content and thus render them suitable for the coking industry.

#### 6. RANIGANJ COALS

Dishergarh and Poniati seam coals, because of their better caking characteristics, seem to be usable in high proportions for the production of metallurgical coke. The behaviour of these coals will be examined further in semi-large-scale and full oven tests.

The satisfactory utilization of the Begonia seam coal by itself, and of the Sanctoria seam to the extent of a 30 per cent blend with normal coke-oven coal mixture, has been confirmed by full oven tests.

Samples from other collieries working these or similar seams will be given further tests.

#### 7. CENTRAL PROVINCES COALS

Of the coals so far tested, those from Hirdagarh, Kalichhaper, Damua and Rakhikol collieries seem to have moderate coking properties. Larger bulk samples of these coals for semi-large-scale and large-scale tests are being taken to verify the laboratory indications.

## 8. ASSAM COALS

Except for their excessive sulphur contents, Assam coals are often of good coking quality and have very little ash. High sulphur content, however, would seem to preclude their utilization for metallurgical purposes. A commercial process is required whereby the sulphur content is reduced appreciably, and the sulphur recovered if possible.

## 9. USE OF COKE-BREEZE IN BLENDS

The use of coke-breeze as a substitute for low volatile coal is practised in certain foreign countries with a view to improvement of the coke quality. In India conditions are different, and the use of coke-breeze along with coking coals has not given promising results. Furthermore, experimental work has shown that its utilization to a limited extent of 2 per cent or so is possible only by fine grinding and by thorough mixing with the blend. Such treatment in practice is difficult and expensive.

E. T. WARREN

*Chairman*

*C.B. & C.R. Sub-Committee*

N. N. DAS GUPTA

*Ag. Secretary*

*C.B. & C.R. Sub-Committee*

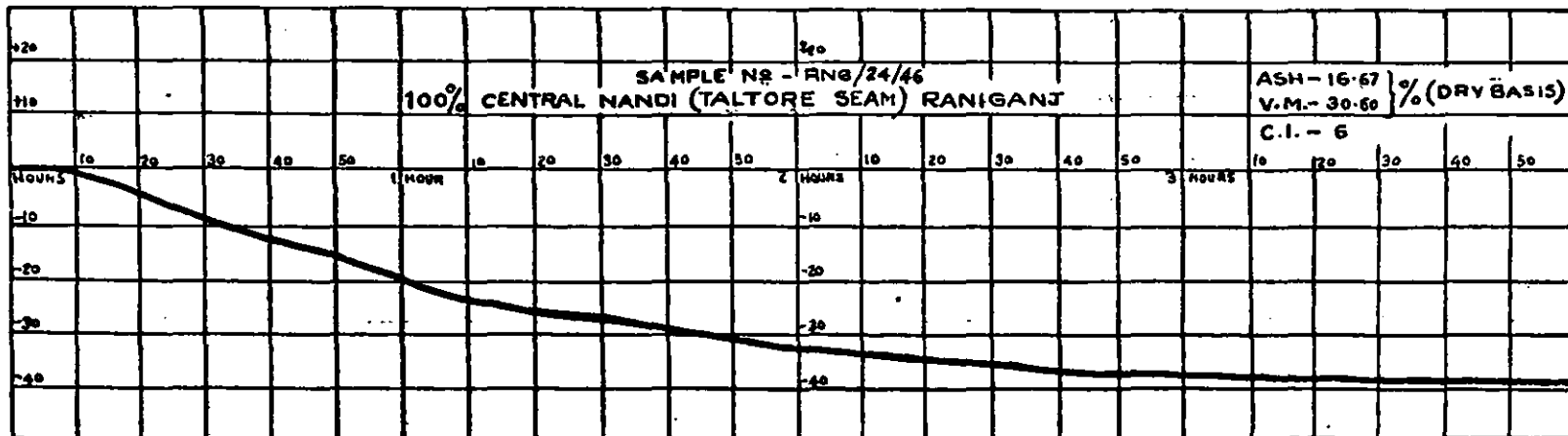

29

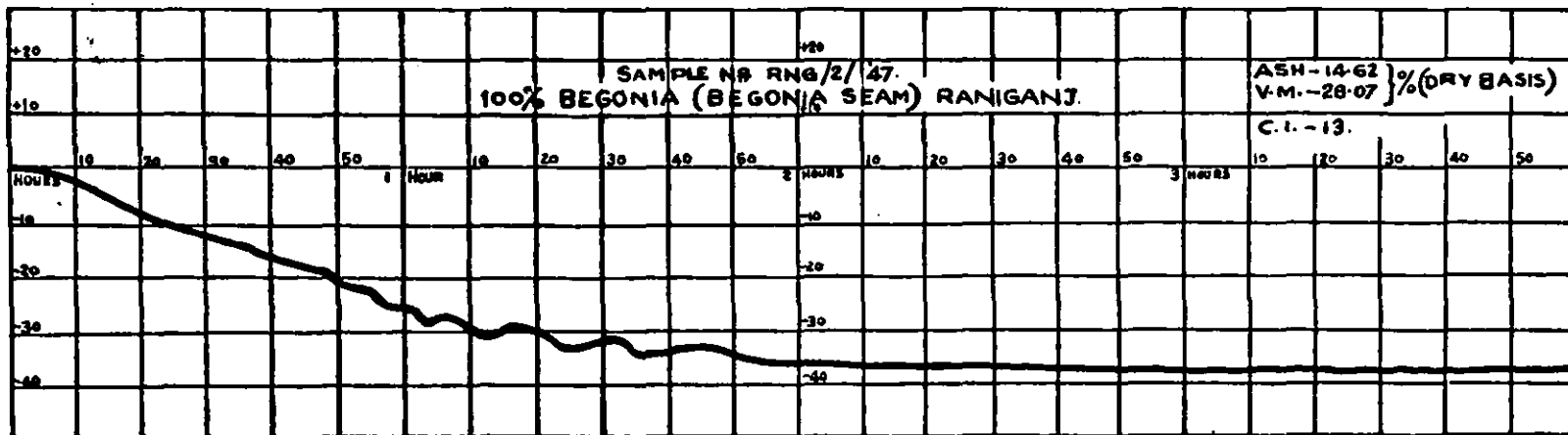

FIGS. 14 AND 15 — TYPICAL CURVES FROM KOPPERS SWELLING TEST

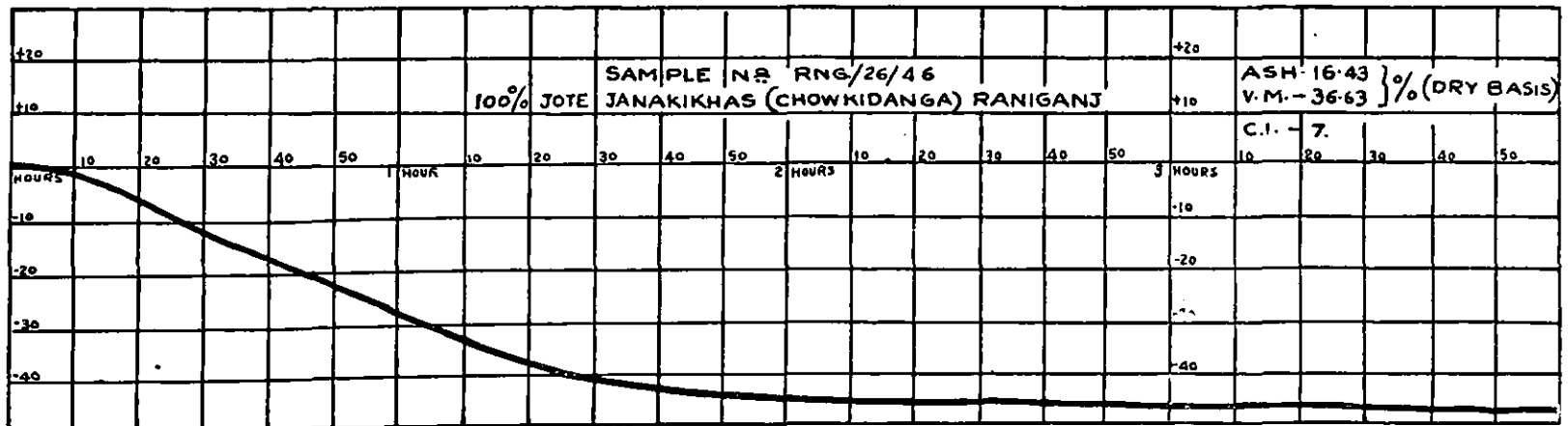
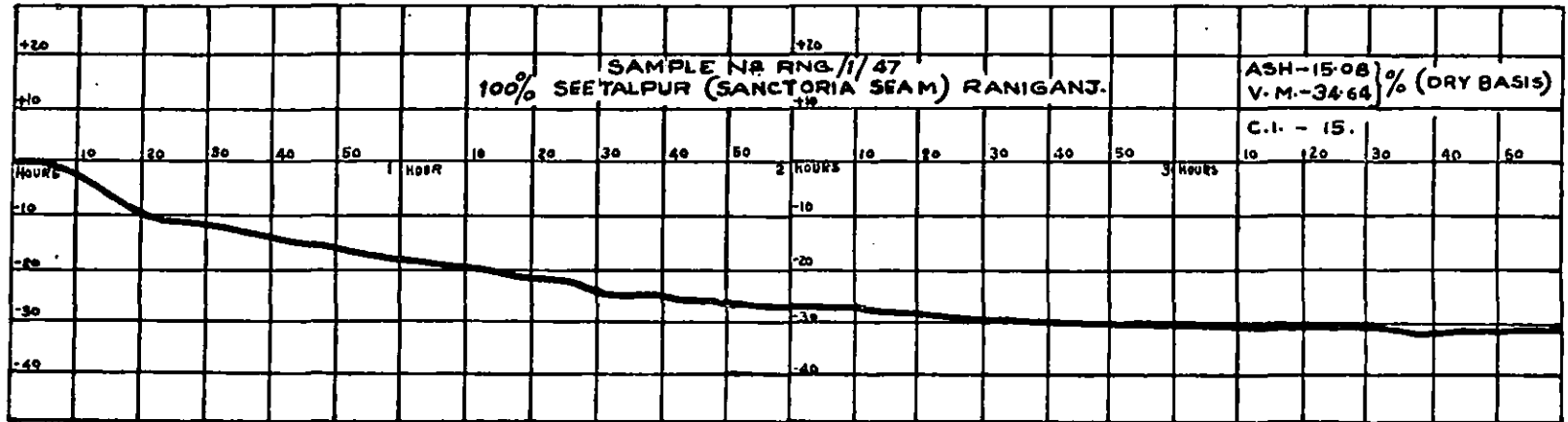

FIGS. 16 AND 17 — TYPICAL CURVES FROM KOPPERS SWELLING TEST

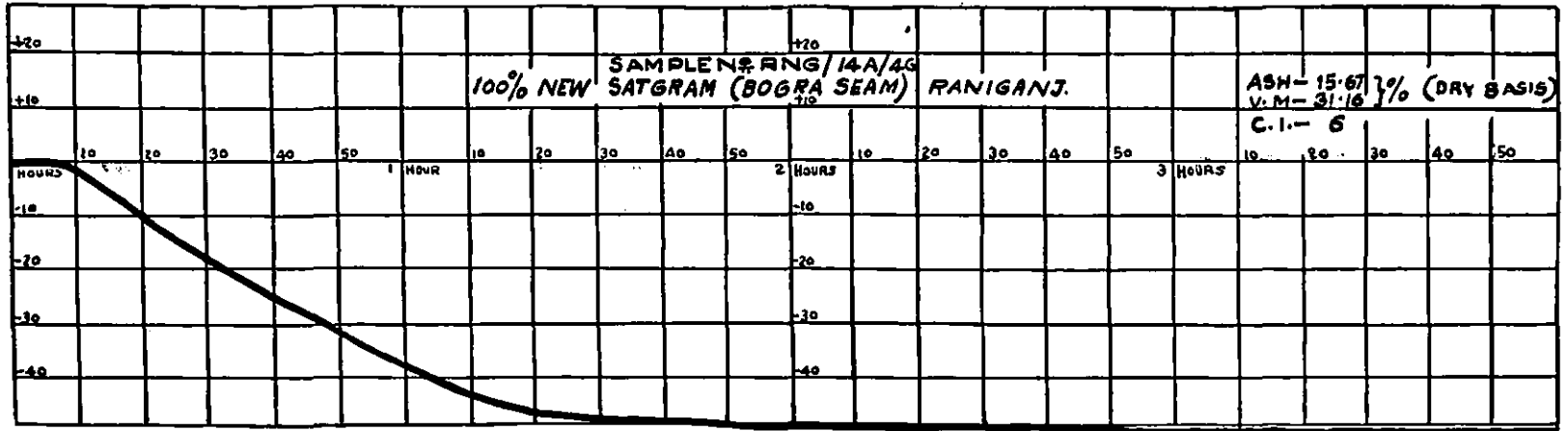

31

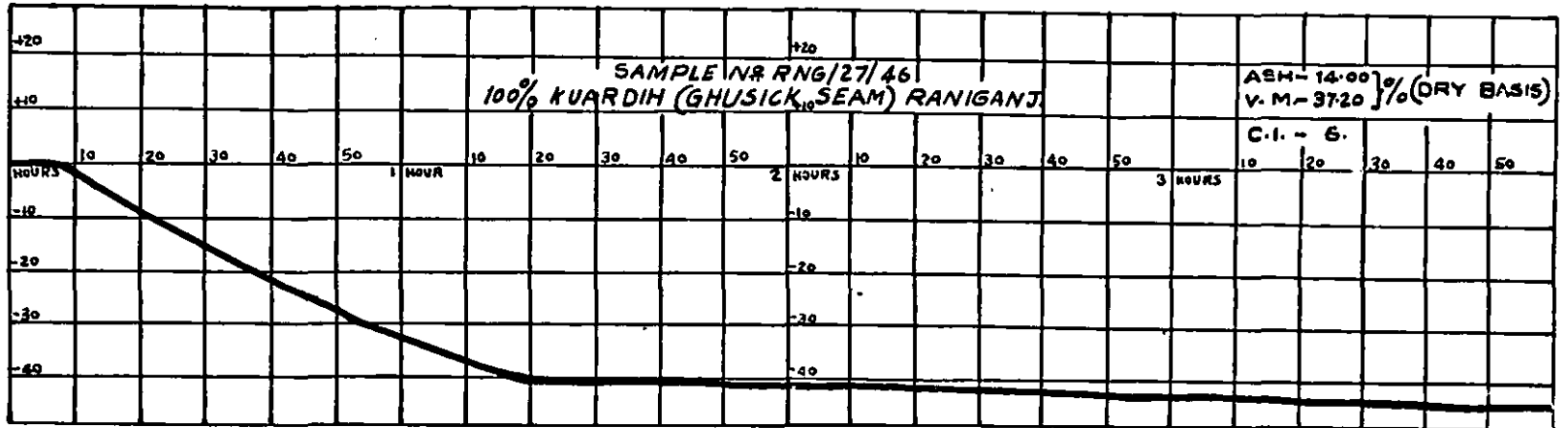

FIGS. 18 AND 19 — TYPICAL CURVES FROM KOPPERS SWELLING TEST



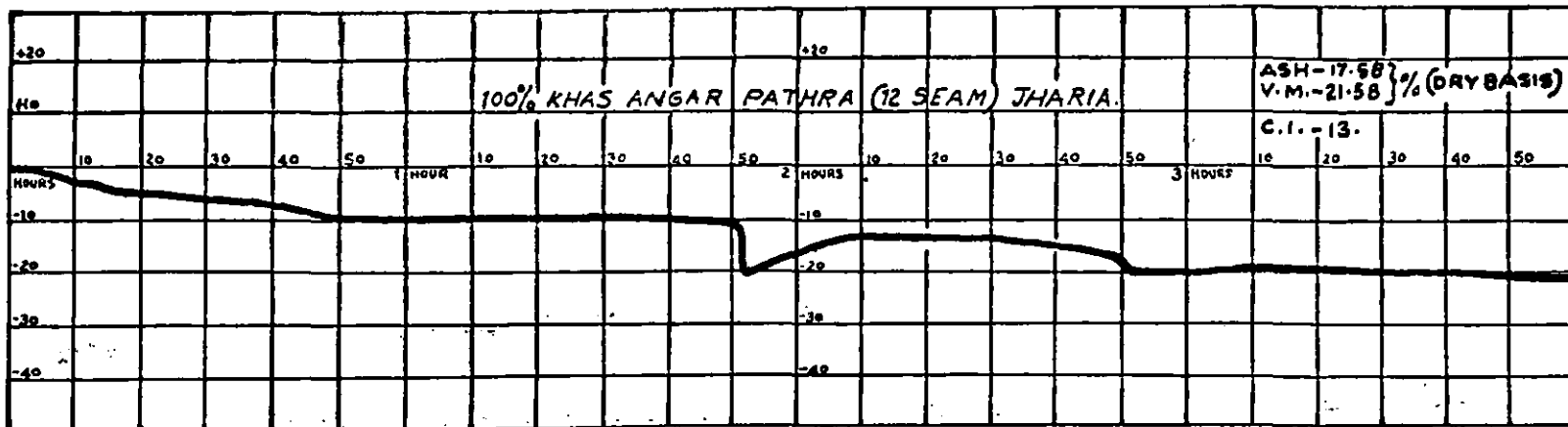

FIG. 20 — TYPICAL CURVE FROM KOPPERS SWELLING TEST

**APPENDIX**  
**TABLES OF RESULTS**

**In the following tables are given the results  
of the laboratory and plant tests.**

TABLE No. 1a—RESULTS OF ANALYSIS OF SUSPECTED SWELLING COALS FROM THE JHARIA FIELD

SERIAL No.	COLLIERY	SRAM	MOISTURE %	ASH %	VOLATILE MATTER %	FIXED CARBON %	TOTAL SULPHUR %	PHOSPHORUS IN COAL %	CAKING INDEX	CALORIFIC VALUE B.Th.U./lb.	FUSION RANGE OF ASH DEG. C	SWELLING TEST		
												Koppers	Nedelmann's Pressure lb./sq. in.	
1	Putkee	...	15	4.5	14.78	26.42	58.80	0.558	0.152	17	...	...	Harmful	5.76
2	Lodna	...	11 & 12	5.5	13.48	27.42	59.10	0.463	0.204	16	...	...	Doubtful	2.55
3	West Ena ( Kerridge Sec.)	...	10	...	13.06	24.58	62.36	0.562	0.126	15	...	...	Doubtful	3.20
4	Gaslitan	...	13	1.2	14.42	23.14	62.44	0.436	0.124	16	...	...	Harmful	5.68
5	do	...	14	1.5	12.64	23.36	64.00	0.528	0.008	16	...	...	Harmless	1.52
6	Jogta	...	12	1.0	12.82	26.34	60.84	0.506	0.202	15	...	...	Harmful	5.62
7	do	...	13	1.7	10.60	23.88	65.52	0.588	0.072	15	...	...	Harmful	4.04
8	East Bhuggutdih	...	11	1.7	14.50	25.64	59.86	0.476	0.046	16	...	...	Harmful	4.20
9	do	...	12	3.8	13.30	23.64	63.06	0.448	0.114	16	...	...	Harmless	1.80
10	Ena	...	10	1.1	13.26	24.04	61.80	0.446	0.224	16	...	...	Doubtful	3.80
11	East Ena	...	11	3.0	15.01	26.45	58.54	0.526	0.048	15	...	...	Harmless	1.88
12	Choitodih	...	13	2.2	16.66	25.56	57.78	0.560	0.172	16	...	...	Doubtful	4.01
13	Loyabad	...	16 & 16A	2.8	13.00	29.26	56.84	0.546	0.082	17	...	...	Doubtful	2.08
14	Patherdih Sudamdih	...	14A	1.6	12.22	27.48	60.30	0.628	0.166	16	...	...	Harmless	0.68
15	do	...	13 & 14	1.6	13.14	27.86	59.00	0.464	0.092	16	...	...	Harmless	1.80
16	Hurriladih	...	16	2.2	12.62	31.82	56.08	0.418	0.226	16	...	...	Harmless	1.80
17	Union Angarpatra	...	12	1.1	14.60	22.66	62.72	0.502	0.136	14	...	...	Harmless	1.00
18	Ballihari 16	...	16	1.4	13.22	28.32	58.46	0.522	0.082	15	...	...	Harmful	2.00
19	Kankanee ( R.O.M. )	...	15	2.2	14.64	25.22	60.14	0.482	0.088	16	12,875	1270 — 1320	Harmless	1.20
20	Bhuggutdih ( R.O.M. )	...	11	2.0	18.04	24.36	57.60	0.544	0.070	15	12,210	1250 — 1300	Harmless	1.70
21	Khas Jharia	...	11	2.0	16.12	25.48	58.40	0.638	0.176	15	12,678	1250 — 1285	Harmless	1.56
22	Sendra Bansjora ( steam )	...	12	1.3	17.00	22.42	60.58	0.699	0.098	15	12,652	1280 — 1310	Harmless	3.70
23	do	...	11	1.6	19.50	21.66	58.84	0.707	0.026	14	12,222	1265 — 1300	Harmless	2.59
24	Ballihari ( slack )	...	13	1.0	14.32	25.88	59.80	0.548	0.112	15	12,056	1275 — 1300	Harmless	3.67
25	Kirkend ( steam )	...	12	2.3	16.74	24.80	58.46	0.675	0.082	14	12,578	1180 — 1210	Harmless	2.30
26	Bhagaband ( steam )	...	16	1.8	16.30	28.66	55.04	0.724	0.078	17	12,628	1290 — 1320	Harmless	1.00
27	East Bhalgora ( slack )	...	12	1.7	18.00	24.24	57.76	0.645	0.205	16	12,541	1180 — 1210	Harmless	5.00
28	New Marine ( R.O.M. )	...	12	2.8	17.50	23.18	59.12	0.757	0.082	13	12,616	1200 — 1230	Harmless	5.60
29	Bhaga ( steam )	...	15	2.0	11.38	23.16	60.46	0.307	0.050	14	13,230	1100 — 1230	Harmless	0.50
30	New Tenturiya ( steam ) ( Dharmaband )	...	13	1.8	16.26	23.66	60.08	0.661	0.092	15	12,696	1150 — 1180	Harmless	2.00
31	Khas Anrapatra ( slack )	...	11	1.9	17.28	23.00	59.72	0.675	0.048	16	12,684	1270 — 1310	Harmless	4.00
32	Loyabad ( R.O.M. )	...	12	2.1	18.10	22.42	59.48	0.571	0.057	15	12,366	1250 — 1290	Harmless	2.50
33	Ramkanalli ( slack )	...	9	2.2	22.04	20.30	57.66	0.429	0.012	11	11,668	1380 — 1410	Harmless	1.50
34	Bhulan Bararee ( steam )	...	12	2.4	15.15	24.99	59.86	0.762	0.086	16	12,836	1280 — 1310	Harmless	1.00
35	Industry ( R.O.M. )	...	10	2.0	23.82	21.03	55.15	0.506	0.107	14	11,309	1320 — 1340	Harmless	1.50

N.B. — All analyses except moisture are reported on dry basis.

**TABLE No. 1b — RESULTS OF LABORATORY BLENDING TESTS WITH  
SUSPECTED SWELLING COALS FROM THE JHARIA FIELD**

SERIAL No.	COLLIERY	SEAM	PROX. ANALYSIS (Dry) %		Coking properties & Caking Index	SWELLING TEST		BLENDING TEST RESULTS WITH	
			Ash	Volatile matter		Koppers	Nedel- mann's Pressure lb./sq. in.	Good coking coals from Jharia*	Coke Breeze from Tata's coke- ovens
1	Loyabad	16 & 16A	13.90	29.26	Good — 17	Doubtful	2.08	10	...
2	Ballihari	16	13.22	28.32	15	Harmful	2.00	10	
3	Putkee	15	14.78	26.42	Good — 17	Harmful	5.76	10	5
4	Gaslitan	13	14.42	23.14	Good — 16	Harmful	5.68	10	...
5	Jogta	13	10.60	23.88	Good — 15	Harmful	4.04	10	...
6	Choitodih	13	16.66	25.56	Good — 16	Doubtful	4.01	10	...
7	Lodna	11 & 12	13.48	27.42	Good — 16	Doubtful	2.55	10	F
8	Jogta	12	12.82	26.34	Good — 15	Harmful	5.62	10	...
9	East Bhuggutdih	11	14.50	25.64	Good — 16	Harmful	4.20	10	...
10	West Ena	10	13.06	24.58	Good — 15	Doubtful	3.20	5	5
11	Ena	10	13.26	24.94	Good — 16	Doubtful	3.80	10	...

\*Good coking coals of harmless swelling properties from Jharia field. The figures indicate the minimum percentage of blending coals or coke-breeze required to offset the harmful swelling properties of the test coals.

TABLE No. 2a — PARTICULARS OF SAMPLES OF "BELOW 10 SEAM"  
COAL FROM THE JHARIA FIELD

SERIAL No.	COLLIERY	PARTICULARS OF SEAM	
		Number	Thickness
KUSUNDA AREA			
1	Sendra Bansjora ...	Special	4'- 0"
2	Gararia ...	Special	2'- 6"
3	Nichitpur ...	Special	4'- 0"
4	Central Gararia ...	Special	4'- 0"
5	Gararia ...	9 Special	3'- 6"
6	Gararia ...	9 Bottom	11'- 0"
7	East Basseria ...	9 Bottom	11'- 8"
8	Gararia ...	9 Top & bottom	19'- 9"
9	Sendra Bansjora ...	9 Top	8'- 0"
10	Central Garaira ...	9 Top	8'- 0"
11	North Basseria ...	9 Top	8'- 0"
12	East Basseria ...	9-A Special	3'-10"
13	North Basseria ...	8	19'- 0"
14	Sendra Bansjora ...	7 Special	4'- 0"
15	North Basseria ...	7 Special	9'- 0"
16	East Basseria ...	7 Special	7'- 6"
17	Nichitpur ...	7	30'- 0"
18	Khas Bansjora ...	7	7'- 0"
19	Pure Nichitpur ...	7	30'- 0"
20	North Basseria ...	5	12'- 0"
21	North Basseria ...	3/4	7'- 0"
TEETULMARI CHANDORE AREA			
1	East Teetulmari ...	Special*	35'- 0"
2	Khas Pandedih ...	8	8'- 0"
3	Central Bansjora ...	8	8'- 0"
4	Pandedih ...	8	8'- 0"
5	Central Bansjora Khas ...	8	8'- 0"
6	Pure Selected Angarpatra ...	8	7'- 0"
7	Chandore ...	8	9'- 4"
8	West Angarpatra ...	8	12'- 0"
9	Central Bansjora ...	7	17'- 3"
10	Pandedih ...	7	18'- 0"
11	Central Bansjora Khas ...	7	17'- 3"
12	Chandore ...	7	16'- 6"
13	Chandore ...	7	16'- 0"
14	North Angarpatra ...	7	17'- 0"
15	Chandore ...	6	12'-14"
16	Pure Selected Bansjora ...	5	18'- 0"
17	Model Angarpatra ...	4	25'- 0"
18	North Teetulmari ...	4	25'- 0"
19	Central Angarpatra ...	4	23'- 0"
20	Pure Selected Teetulmari ...	3†	27'- 0"
21	Upper Bansjora ...	3	7'- 0"
KATRASGARH AREA			
1	East Salanpur ...	9 Special	11'- 0"
2	West Salanpur ...	9 Bottom	15'- 0"
3	Lukerka Khas ...	9 Bottom	15'- 0"
4	North Salanpur ...	9 Bottom	7'- 0"
5	Central Salanpur ...	9 Bottom	12'- 0"
6	New Lakurka ...	9	12'- 0"
7	Salanpur ...	9	12'- 0"
8	North Salanpur ...	9	12'- 0"
9	Joint Salanpur ...	9	12'- 0"
10	Central Salanpur ...	9	12'- 0"
11	Khas Govindapur ...	9	11'- 0"
12	East Katrasgarh ...	9	9'- 0"
13	Khas Methadih ...	9	9'- 0"
14	Khas Methadih ...	8	11'- 0"
15	Khas Govindapur ...	7 Specia	6'- 6"
16	West Katras ...	7 Middle	7'- 0"
17	North Akaskanaree ...	7 Middle	6'- 6"
18	North Akaskanaree ...	7 Top	9'- 9"
19	New Salanpur ...	7 Top	12'- 0"
20	North Tetulia ...	5	22'- 0"
NAWAGARH AREA			
1	Berwabera ...	9 Special	6'- 0"
2	Pure Joyramdih ...	9 Special	5'- 0"
3	Khas Kenduadih ...	9 Bottom	6'- 6"
4	Selected Phularitand ...	9 Bottom	8'- 0"
5	Khas Kenduadih ...	9	7'- 6"
6	Selected Phularitand ...	9	7'- 6"
7	Central Joyramdih ...	9	11'- 3"
8	Khas Joyramdih ...	9	12'- 3"
9	Pure Joyramdih ...	9	11'- 8"

\* Rather No. 2 Seam. Thickness not fully verified.

† Rather No. 2. Seam.

TABLE No. 2a — PARTICULARS OF SAMPLES OF "BELOW 10 SEAM"  
GOAL FROM THE JHARIA FIELD — (continued)

SERIAL No.	COLLIERY	PARTICULARS OF SEAM	
		Number	Thickness
10	Selected Phularitand	8	10'- 0"
11	Berwabera	8	11'- 0"
12	Khas Phularitand	8	10'- 0"
13	West Phularitand	7 (sec. 4)	9'- 0"
14	South Barora	7 (sec. 4)	11'- 0"
15	East Benedih	7 (sec. 4)	11'- 0"
16	Central Kenduadih	7 (sec. 4)	11'- 0"
17	Pure Ganespur	7 (sec. 4)	11'- 0"
18	North Sinidih	7 (sec. 3)	8'- 0"
19	Pinalgora	7 (sec. 4)	9'- 0"
20	Upper Mandra	7 (sec. 2)	4'- 6"
21	Barora	7 (sec. 2)	5'- 4"
22	Pure Barora	7 (sec. 2)	5'- 0"
23	Upper Mandra	7 (sec. 1)	6'- 0"
24	Pure Benedih	7 (sec. 1)	7'- 0"
25	North Barornasia	7 (sec. 1)	6'- 0"

NUDKHURKEE KARMATAND AREA

1	Joyramdih	9 Special	5'- 3"
2	Joyramdih	9	12'- 6"
3	New Joyramdih	9	12'- 6"
4	Nudkharkee	9	12'- 0"
5	Matigora	9	15'- 0"
6	Bokaro Jharia	9	...
7	Karmatand	9 Bottom	9'- 0"
8	New Joyramdih	8	12'- 0"
9	Isabella	7 Special	11'- 0"
10	Pure Damuda	7 (sec. 1 & sec. 2)	4'- 0"
			2'- 0"
11	Pure Damuda	7 (sec. 4)	12'- 0"
12	Pure Damuda	7 (sec. 5)	5'- 6"
13	Karmatand	5,6,7 Comb. (sec. 4)	9'- 0"
14	Karmatand	5,6,7 Comb. (sec. 5)	7'- 0"

DHANSWAR DOBARI JHARIA AREA

1	Dondudih	9	10'- 0"
2	Dobari	9	9'- 0"
3	Khas Jharia Dobari	9	8'- 0"
4	Khas Bhuggutdih	9 (bot. sec.)	9'- 0"
5	Khas Bhuggutdih	7 & 8	12'- 0"
6	Dobari	7 & 8	18'- 0"
7	North Dobari	7 & 8	40'- 0"
8	Khas Jharia Dobari...	7 & 8 (mid. sec.)	18'- 0"
9	East Godhur	5 Top	7'- 6"
10	Dhanswar North Bhuggutdih	5 Top	5'- 0"
11	Dhanswar North Bhuggutdih	5 (mid.)	8'- 6"
12	Dhanswar	5 (mid.)	22'- 0"
13	East Godhur	5 (bot. sec.)	7'- 6"
14	Dhanswar North Bhuggutdih	5 (bot. sec.)	7'- 6"
15	Dhanswar	5 (bot. sec.)	10'- 0"
16	Dhanswar	5 (sec. 2)	15'- 0"
17	Dhanswar	5 (sec. 3)	12'- 0"
18	Haripur	1	5'- 0"

TISRA JENAGORA AREA

1	North Kujama	10A	12'- 0"
2	Central Jenagora	9A	9'- 6"
3	Golakdih	9	12'- 0"
4	Kalithan Jenagora	9	10'- 0"
5	New Jenagora	9	8'- 0"
6	Tisra	8	8'- 0"
7	Tisra	8	52'- 0"
8	Tisra	8	52'- 0"
9	Lower Upper Jharia	8	52'- 0"
10	Indian Jharia	8	8'- 0"
11	Central Jharia	8	10'- 0"
12	Tisra	7	52'- 0"
13	Tisra	7	52'- 0"
14	Tisra	7	52'- 0"
15	Bengal Jharia	7	52'- 0"
16	Lower Upper Jharia	7	52'- 0"
17	South Tisra	7	8'- 0"
18	Indian Jharia	7	52'- 0"
19	South Golakdih	7	52'- 0"
20	Central Jharia	7	10'- 0"

TABLE No. 2b — RESULTS OF ANALYSIS OF COALS FROM SEAMS BELOW 10, JHARIA COALFIELD\*

SERIAL No.†	MOISTURE %	ASH %	VOLATILE MATTER %	FIXED CARBON %	TOTAL SULPHUR %	PHOSPHORUS IN COAL %	CAKING INDEX	B.T.H./LB.	SWELLING TEST (KOPPERS)	FUSION RANGE OF ASH DEG. C.	COLOUR OF ASH
KUSUNDA AREA											
1	0.70	25.08	18.64	55.38	0.323	0.026	12	11,214	Harmless	1350 — 1400	Bright white
2	0.80	15.58	21.64	62.78	0.050	0.038	17	12,850	"	1450 — 1490	Pinkish white
3	0.70	21.72	19.00	59.28	0.611	0.026	13	11,843	"	1330 — 1370	White
4	0.80	19.10	20.76	60.08	0.730	0.064	16	12,303	"	1410 — 1440	"
5	1.00	22.02	19.46	58.52	0.616	0.132	10	11,782	"	1310 — 1360	Pinkish white
6	0.70	30.22	17.65	52.13	0.416	0.032	9	10,425	"	1446 — 1490	"
7	1.00	33.88	17.40	48.72	0.247	0.038	6	9,630	"	1440 — 1480	"
8	0.80	27.10	18.52	54.38	0.520	0.064	10	11,024	"	1330 — 1380	Dull white
9	1.00	22.56	18.64	58.80	0.488	0.033	12	11,708	"	1420 — 1450	"
10	0.80	21.08	20.00	58.02	0.520	0.048	12	11,706	"	1230 — 1270	White
11	1.00	22.16	20.40	57.44	0.457	0.393	5	11,221	"	1410 — 1440	Pinkish white
12	0.80	17.40	20.68	61.92	0.687	0.146	17	12,654	"	1340 — 1380	"
13	0.90	33.12	16.68	50.20	0.293	0.062	4	9,691	"	1280 — 1330	"
14	0.80	29.82	17.08	53.10	0.414	0.156	4	10,228	"	1290 — 1340	"
15	1.00	30.70	19.88	49.42	0.267	0.035	6	10,092	"	1180 — 1240	Pink
16	0.80	19.48	19.36	61.16	0.463	0.020	14	12,239	"	1220 — 1260	"
17	0.70	20.68	19.40	59.92	0.441	0.022	15	12,072	"	1420 — 1450	Dull white
18	0.60	30.86	15.80	53.34	0.463	0.020	8	10,382	"	1400 — 1440	White pinkish
19	0.60	18.68	22.22	59.10	0.482	0.074	17	12,456	"	1290 — 1330	Pinkish white
20	1.30	37.10	14.95	47.95	0.438	0.016		9,128	"	1430 — 1470	"
21	1.20	28.93	16.66	54.41	0.367	0.028	8	10,610	"	1410 — 1440	Dull white
TEETULMARI CHANDORE AREA											
1	0.66	28.70	16.20	55.10	0.427	0.144	6	10,370	"	1270 — 1320	White
2	1.10	23.84	19.20	56.96	0.416	0.292	10	11,598	"	1270 — 1320	Pinkish white
3	1.05	24.04	18.52	57.44	0.608	0.164	10	11,476	"	1280 — 1330	White
4	0.80	21.84	20.36	57.80	0.425	0.382	13	11,842	"	1250 — 1300	"
5	0.92	20.04	22.02	57.94	0.567	0.274	14	12,120	"	1240 — 1290	Pinkish white
6	0.54	24.40	20.24	55.36	0.419	0.056	11	11,440	"	1320 — 1360	White
7	1.00	26.28	21.03	52.64	0.375	0.348	9	11,170	"	1210 — 1250	Pinkish white
8	0.92	28.04	20.28	51.68	0.411	0.030	4	10,484	"	1340 — 1400	"
9	0.64	24.32	19.34	56.34	0.395	0.054	10	11,430	"	1380 — 1430	White
10	0.68	24.34	18.20	57.46	0.351	0.036	7	11,350	"	1320 — 1370	"
11	0.90	31.38	18.00	56.62	0.468	0.042	5	9,950	"	1350 — 1400	Pinkish white
12	1.02	29.78	19.52	50.70	0.361	0.102	6	10,225	"	1330 — 1360	"
13	1.80	24.04	20.10	55.86	0.411	0.026	3	10,940	"	1330 — 1370	"
14	0.74	28.40	17.92	53.68	0.411	Traces	6	10,430	"	1320 — 1360	"

\* All analyses except moisture are reported on dry basis.

† Refer to corresponding serial No. in Table No. 2a.

TABLE No. 2b — RESULTS OF ANALYSIS OF COALS FROM SEAMS BELOW 10, JHARIA COALFIELD\* — (continued)

SERIAL No.†	MOISTURE %	ASH %	VOLATILE MATTER %	FIXED CARBON %	TOTAL SULPHUR %	PHOSPHORUS IN COAL %	CAKING INDEX %	B.T.R.U./LB.	SWELLING TEST (KOPFERS)	FUSION RANGE OF ASH DEG. C.	COLOUR OF ASH
15	0.52	35.34	16.30	47.86	0.387	0.092	4	9,420	Harmless	1130 — 1340	White
16	0.66	31.72	16.10	52.18	0.397	0.074	4	9,890	"	1390 — 1430	"
17	0.64	29.18	18.64	52.20	0.425	0.054	5	10,300	"	1360 — 1400	Pink
18	0.82	27.10	16.54	56.36	0.613	0.048	6	10,600	"	1380 — 1420	White
19	0.72	25.10	17.46	57.44	0.512	0.092	8	11,240	"	1290 — 1340	"
20	1.54	24.48	18.60	56.92	0.480	0.034	7	11,320	"	1380 — 1420	"
21	0.63	26.00	16.08	57.92	0.510	0.072	6	10,880	"	1280 — 1320	Dull white
KATRASGARH AREA											
1	1.08	18.58	20.90	60.52	0.394	0.068	12	12,320	"	1390 — 1430	White
2	0.88	24.50	18.16	57.34	0.500	0.016	9	11,300	"	1340 — 1390	Pinkish white
3	1.00	25.68	18.38	55.94	0.482	0.020	9	11,120	"	1400 — 1440	White
4	0.75	26.00	19.57	54.43	0.517	Traces	13	11,220	"	1360 — 1390	"
5	0.88	22.24	20.10	57.66	0.362	0.012	12	11,760	"	1330 — 1380	Pinkish
6	0.74	24.32	20.40	54.78	0.450	0.032	8	11,240	"	1340 — 1380	"
7	0.92	24.70	19.86	55.44	0.370	0.024	9	11,270	"	1340 — 1380	Pinkish white
8	0.84	22.40	20.12	57.48	0.451	0.032	10	11,610	"	1330 — 1380	Pinkish white
9	0.68	22.02	20.14	57.84	0.445	0.028	9	11,620	"	1380 — 1420	White
10	1.00	22.48	20.00	57.52	0.428	0.048	11	11,710	"	1340 — 1390	Pinkish white
11	0.82	26.14	19.34	54.52	0.396	0.104	7	11,020	"	1340 — 1390	White
12	0.78	17.66	21.56	60.78	0.474	0.020	15	12,540	"	1360 — 1390	Pinkish white
13	0.72	24.10	20.34	55.56	0.364	0.044	11	11,480	"	1380 — 1420	"
14	0.82	31.66	18.40	49.94	0.320	0.020	6	10,080	"	1370 — 1410	White
15	0.96	19.40	20.22	60.38	0.420	0.130	13	12,240	"	1320 — 1350	"
16	0.84	18.66	20.02	61.32	0.428	0.186	12	12,320	"	1360 — 1390	"
17	0.70	24.86	19.64	55.50	0.397	0.064	11	11,380	"	1360 — 1390	Pinkish white
18	0.80	27.56	19.64	52.80	0.375	0.117	7	10,790	"	1350 — 1380	"
19	0.85	30.40	17.00	52.60	0.440	0.058	8	10,320	"	1380 — 1420	"
20	0.64	22.04	19.46	58.50	0.378	0.104	11	11,790	"	1340 — 1370	White
NAWAGARH AREA											
1	0.72	23.32	18.80	52.88	0.424	0.012	6	10,540	"	1320 — 1360	White
2	0.82	28.00	18.44	53.56	0.420	0.030	8	10,800	"	1350 — 1400	"
3	0.76	29.60	17.74	52.66	0.426	0.026	8	10,590	"	1320 — 1370	"
4	0.82	26.92	19.44	53.64	0.398	0.024	8	11,010	"	1300 — 1340	Pinkish
5	0.84	27.60	19.20	53.20	0.434	0.024	7	10,900	"	1300 — 1350	White
6	0.94	28.80	18.38	52.82	0.383	0.022	6	10,480	"	1350 — 1400	Dull white
7	0.96	30.04	19.60	50.36	0.400	0.026	8	10,380	"	1120 — 1170	Pinkish white
8	0.68	24.62	18.70	56.68	0.446	0.048	6	11,110	"	1280 — 1320	White

\* All analyses except moisture are reported on dry basis.

† Refer to corresponding serial No. in Table No. 2a.



TABLE No. 2b — RESULTS OF ANALYSIS OF COALS FROM SEAMS BELOW 10, JHARIA COALFIELD\* — (continued)

SERIAL No.†	MOISTURE %	ASH %	VOLATILE MATTER %	FIXED CARBON %	TOTAL SULPHUR %	PHOSPHORUS IN COAL %	CAKING INDEX	B.Th.U./LB.	SWELLING TEST (KOPPERS)	FUSION RANGE OF ASH DEG. C.	COLOUR OF ASH
9	0.94	26.34	18.28	55.38	0.454	0.028	8	11,060	Harmless	1260 — 1310	Pinkish white
10	0.96	34.72	17.92	47.36	0.397	0.036	5	9,600	"	1280 — 1330	White
11	0.94	23.14	20.12	56.74	0.466	0.026	8	11,500	"	1230 — 1280	Pinkish white
12	0.84	29.40	20.74	49.86	0.416	0.018	5	10,380	"	1130 — 1180	Pink
13	0.92	22.96	19.34	58.70	0.454	0.172	8	11,520	"	1180 — 1230	Dull white
14	0.92	20.12	19.64	60.24	0.438	0.224	9	12,040	"	1190 — 1230	"
15	0.68	16.45	21.24	62.31	0.472	0.200	12	12,630	"	1200 — 1230	"
16	0.75	21.56	20.20	58.24	0.466	0.160	9	11,830	"	1180 — 1220	Pinkish white
17	0.68	21.36	18.64	60.00	0.460	0.054	9	11,860	"	1200 — 1240	"
18	0.84	34.28	17.36	48.36	0.337	0.068	4	9,570	"	1270 — 1310	"
19	0.84	26.18	17.56	56.26	0.395	0.196	8	11,090	"	1220 — 1250	Dull white
20	0.82	25.90	21.16	52.94	0.397	0.256	7	11,100	"	1080 — 1120	Ash
21	0.84	25.55	19.60	54.85	0.356	0.244	8	11,180	"	1180 — 1220	Pinkish white
22	0.82	26.60	19.80	53.60	0.356	0.190	7	10,990	"	1150 — 1200	"
23	0.80	31.14	18.80	50.06	0.367	0.064	5	10,110	"	1130 — 1170	"
24	1.00	23.38	17.96	53.66	0.403	0.136	7	10,720	"	1250 — 1280	Pinkish
25	0.70	27.92	18.20	53.88	0.360	0.100	6	10,600	"	1240 — 1280	Dull white
NUDKHURKEE KARMATAND AREA											
1	0.92	28.40	17.80	55.80	0.441	0.012	8	10,980	"	1340 — 1370	Pinkish white
2	0.88	28.20	17.34	54.46	0.392	0.014	6	10,730	"	1240 — 1290	"
3	0.78	23.28	17.60	59.14	0.449	0.020	4	11,470	"	1350 — 1400	Pink
4	0.96	20.54	18.28	52.18	0.372	0.028	4	10,240	"	1190 — 1250	Pinkish
5	1.04	22.14	19.60	58.26	0.498	0.016	9	11,650	"	1200 — 1250	Pinkish white
6	0.88	22.42	18.76	58.82	0.473	0.068	7	11,590	"	1240 — 1280	White
7	0.74	20.90	18.40	54.70	0.500	0.064	9	10,910	"	1250 — 1290	"
8	0.76	23.24	17.68	54.08	0.341	0.018	16	10,670	"	1340 — 1380	Pink
9	1.00	18.98	17.76	63.20	0.436	0.134	10	12,200	"	1200 — 1250	Pinkish
10	0.84	21.86	18.64	59.50	0.411	0.216	11	11,670	"	1150 — 1190	"
11	0.76	24.82	18.02	57.16	0.452	0.111	10	11,330	"	1220 — 1270	Ash
12	0.88	23.84	15.60	60.56	0.258	0.120	4	11,200	"	1290 — 1330	Dull white
13	0.98	23.10	15.66	56.24	0.395	0.048	6	10,680	"	1320 — 1360	White
14	0.92	25.80	17.06	57.14	0.471	0.020	6	10,990	"	1400 — 1440	Dull white
DHANSWAR DOBARI JHARIA AREA											
1	1.00	23.86	18.82	52.62	0.351	0.064	6	10,570	"	1340 — 1400	Pink
2	0.98	26.34	19.30	54.36	0.397	0.026	6	10,900	"	1380 — 1420	Pinkish white
3	0.84	24.32	20.00	55.68	0.447	0.024	9	11,330	"	1320 — 1360	Pinkish
4	0.94	27.64	18.74	53.62	0.422	Traces	7	10,650	"	1350 — 1400	Cream white

\* All analyses except moisture are reported on dry basis.

† Refer to corresponding serial No. in Table No. 2a.

TABLE No. 2b — RESULTS OF ANALYSIS OF COALS FROM SEAMS BELOW 10, JHARIA COALFIELD\* — (continued)

SERIAL † No.	MOISTURE %	ASH %	VOLATILE MATTER %	FIXED CARBON %	TOTAL SULPHUR %	PHOSPHORUS IN COAL %	CAKING INDEX	B.T.H.U./ LB.	SWELLING TEST (KOPPERS)	FUSION RANGE OF ASH DEG. C.	COLOUR OF ASH
5	0.84	27.56	18.80	53.64	0.348	0.108	7	10,600	Harmless	1340 — 1380	Cream white
6	0.90	24.56	19.64	55.80	0.302	0.144	9	11,320	"	1280 — 1320	Dull white
7	0.78	22.52	19.00	58.48	0.375	0.124	9	11,020	"	1230 — 1280	Pinkish
8	0.82	27.06	19.50	53.44	0.348	0.118	8	10,730	"	1350 — 1400	Pinkish white
9	1.10	21.82	17.48	61.70	0.477	0.018	5	11,550	"	1230 — 1280	Pinkish
10	0.96	31.44	17.38	51.18	0.384	0.046	5	10,160	"	1340 — 1380	Pinkish white
11	0.82	22.42	18.92	58.66	0.419	0.098	9	11,640	"	1290 — 1340	"
12	0.92	25.80	18.60	55.60	0.348	0.256	6	10,980	"	1140 — 1180	"
13	0.84	30.10	16.86	53.04	0.447	0.078	5	10,350	"	1280 — 1340	Ash
14	0.88	23.90	18.40	57.70	0.436	Traces	7	11,290	"	1200 — 1240	Pink
15	0.88	23.60	19.06	57.44	0.373	0.070	6	11,320	"	1220 — 1270	Pink white
16	0.82	21.90	19.16	58.94	0.345	0.104	8	11,610	"	1240 — 1270	"
17	0.76	21.76	19.40	58.84	0.433	0.138	9	11,660	"	1140 — 1180	"
18	0.94	19.50	19.30	61.20	0.526	0.028	8	11,960	"	1170 — 1200	Pink
TISRA JENAGORA AREA											
1	0.94	30.04	19.36	50.60	0.469	0.098	8	10,380	"	1380 — 1420	Dull white
2	0.96	30.64	18.96	50.40	0.381	0.042	18	10,300	"	1350 — 1380	White
3	0.88	25.20	20.66	54.14	0.463	0.012	11	11,200	"	1360 — 1400	Pink white
4	0.70	20.46	24.02	55.52	0.529	0.014	13	12,050	"	1350 — 1390	"
5	0.98	23.94	21.52	54.54	0.414	0.054	9	11,320	"	1360 — 1400	Dull white
6	0.90	24.60	21.40	54.00	0.395	Traces	9	11,320	"	1420 — 1460	Bright white
7	0.82	26.44	21.10	52.46	0.395	"	9	11,020	"	1400 — 1450	"
8	0.88	23.02	21.74	55.24	0.408	0.020	10	11,580	"	1420 — 1460	"
9	0.96	24.34	20.14	55.52	0.403	0.012	10	11,400	"	1400 — 1440	Dull white
10	0.82	22.72	21.16	56.12	0.403	0.036	10	11,540	"	1390 — 1420	Bright white
11	1.10	25.82	20.44	53.74	0.328	0.030	8	11,030	"	1340 — 1380	White
12	0.84	31.60	20.70	47.70	0.345	0.022	7	10,190	"	1240 — 1280	Pink white
13	0.92	25.86	20.46	53.68	0.343	0.008	8	11,000	"	1180 — 1220	Pink
14	0.78	23.74	21.72	54.54	0.384	0.056	9	11,400	"	1240 — 1280	Ash white
15	0.74	27.48	20.58	51.94	0.323	0.016	7	10,780	"	1410 — 1460	Bright white
16	0.92	21.94	20.64	57.42	0.318	0.144	9	11,660	"	1200 — 1240	White
17	0.84	27.66	20.57	51.77	0.352	0.026	7	10,750	"	1390 — 1430	Dull white
18	0.92	25.98	20.68	53.34	0.326	0.018	9	11,100	"	1190 — 1230	"
19	0.94	25.58	20.84	53.58	0.321	0.018	8	11,080	"	1130 — 1220	Pink white
20	1.00	26.80	22.16	51.54	0.304	0.240	8	10,960	"	1170 — 1220	Dull white

\* All analyses except moisture are reported on dry basis.

† Refer to corresponding serial No. in Table No. 2a.

TABLE No. 2c — SUMMARY OF RESULTS OF LABORATORY BLENDING TEST WITH JHARIA COALS FROM SEAMS BELOW 10

SERIAL No.	COLLIERY	SEAM	PROX. ANALYSIS (DRY) %		COKING PROPERTIES & COKING INDEX	BLENDING TEST RESULTS WITH COKING COALS*							
			Ash	V.M.		LOW VOLATILE COALS			MEDIUM VOLATILE COALS			HIGH VOLATILE COALS	
						Sijua	Choitodih	Malkera	Ramnagar	Chanch	W.Bokaro	Bhatdee	Murulidih
KUSUNDA AREA													
1	East Basseria	7 Special	19.48	19.36	Fair — 14	30 to 50	40	50	60	20	20	30	50
2	Nichitpur	Special	21.72	19.00	Fair — 13	20 to 30	20	20	20	10	20	10	20
3	Sendra Bansjora	Special	25.98	18.64	Semi — 12	20 to 30	20	20	30	20	...	Not done	...
4	Sendra Bansjora	9 Top	22.56	18.64	Semi — 12	20 to 30	20	20	20	10	20	10	10
5	Central Gararia	9 Top	21.98	20.00	Semi — 12	20 to 30	20	20	20	10	20	10	20
6	Gararia	9 Special	22.02	19.46	Semi — 10	20 to 30	10	20	10	10	10	10	10
7	Gararia	9 Top & bot.	27.10	18.52	Semi — 10	30	20	20	30	10	...	Not done	...
8	North Basseria	3/4	23.98	18.06	Semi — 8	20	20	20	30	20	...	Not done	...
9	North Basseria	9 Top	22.16	20.40	Poor — 5	10 to 20	10	10	10	...	10	10	...
10	Sendra Bansjora	7 Special	29.82	17.08	Poor — 4	10 to 20	20	10	30	10	...	Not done	...
TEETULMARI CHANDORE AREA													
1	Central Bansjora Khas	8	20.04	22.02	Fair — 14	40	30	40	30	10	10	10	30
2	Pandedih	8	21.84	20.36	Fair — 13	20	20	20	20	10	20	10	20
3	Pure Selected Angarpatra	8	24.40	20.24	Semi — 11	20 to 30	20	10	10	10	10	10	10
4	Khas Pandedih	8	23.84	19.20	Semi — 10	20	10	10	10	10	10	10	10
5	Central Bansjora	8	24.04	18.52	Semi — 10	10 to 20	20	10	10	10	10	10	10
6	Central Bansjora	7	24.32	19.34	Semi — 10	10 to 20	10	10	10	10	10	10	10
7	Chandore	8	26.28	21.08	Semi — 9	20 to 30	20	20	30	20	...	Not done	...
8	Central Angarpatra	4	25.10	17.46	Semi — 8	10 to 20	20	20	20	10	...	Not done	...
9	Pandedih	7	24.34	18.20	Poor — 7	10 to 20	10	10	10	N	10	10	N
10	Pure Selected Teetulmari	3	24.48	18.60	Poor — 7	10 to 20	10	10	10	N	10	10	N
11	East Teetulmari	Special	28.70	16.20	Poor — 6	10 to 30	20	10	30	10	...	Not done	...
12	Chandore	7	29.78	19.52	Poor — 6	10	N	N	10	N	N	N	N
13	North Angarpatra	7	28.40	17.92	Poor — 6	10 to 20	20	10	30	N	...	Not done	...
14	North Teetulmari	4	27.10	16.54	Poor — 6	10 to 20	20	10	20	10	...	Not done	...
15	Upper Bansjora	3 Special	26.00	16.08	Poor — 6	10 to 20	10 to 20	10	30	10	...	Not done	...
16	Model Angarpatra	4	29.16	18.64	Poor — 5	10	10	10	20	10	...	Not done	...
17	West Angarpatra	8	28.04	20.28	Poor — 4	20	10	10	30	...	...	Not done	...
18	Chandore	7	24.04	20.10	Non-Coking 3	10 to 30	20	10	30	20	...	Not done	...

\* Figures indicate maximum percentage of test coals usable in blends to produce satisfactory coke. — See Table No. 2d for analysis of coking coals.  
N = Not even 10 per cent of the test coals was found usable.

TABLE No. 2c — SUMMARY OF RESULTS OF LABORATORY BLENDING TEST WITH JHARIA COALS — (continued)

SERIAL No.	COLLIERY	SEAM	PROX. ANALYSIS (Dry) %		COKING PROPERTIES & CAKING INDEX	BLENDING TEST RESULTS WITH COKING COALS*							
			Ash	V.M.		LOW VOLATILE COALS			MEDIUM VOLATILE COALS			HIGH VOLATILE COALS	
						Sijua	Choitodih	Malkera	Ramnagar	Chanch	W.Bokaro	Bhatdee	Murulidih
KATRASGARH AREA													
1	North Salanpur	9 Bottom	26.00	19.57	Fair — 13	30	...	...	...	Not done	...	...	...
2	Khas Govindapur	7 Special	19.40	20.22	Fair — 13	40 to 50	40	50	60	40	20	30	50
3	East Salanpur	9 Special	18.53	20.90	Semi — 12	30 to 50	30	40	50	20	20	20	50
4	Central Salanpur	9 Bottom	22.24	20.10	Semi — 12	30	20	20	30	N	N	N	20
5	West Katras	7 Middle	18.66	20.02	Semi — 12	30 to 50	30	40	50	20	20	20	40
6	Central Salanpur	9	22.48	20.00	Semi — 11	30	20	30	30	N	10	10	20
7	Khas Methadih	9	24.10	20.34	Semi — 11	30 to 40	30	30	30	10	10	10	20
8	North Akaskenaree	7 Middle	24.86	19.64	Semi — 11	20 to 30	20	20	30	N	N	N	20
9	North Tetulia	5	22.04	19.46	Semi — 11	20 to 30	20	20	30	N	N	10	18
10	North Salanpur	9	22.40	20.12	Semi — 10	20	20	20	20	N	N	N	20
11	West Salanpur	9 Bottom	24.50	18.16	Semi — 9	20	20	20	20	N	N	N	20
12	Lakurka Khas	9 Bottom	25.68	18.38	Semi — 9	20	...	...	...	Not done	...	...	...
13	Salanpur	9	24.70	19.86	Semi — 9	20	20	20	20	N	N	N	10
14	Joint Salanpur	9	22.02	20.14	Semi — 9	20	20	20	20	N	N	N	30
15	New Lakurka	9	24.32	20.40	Semi — 8	10 to 20	20	10	30	N	N	N	20
16	Khas Govindapur	9	26.14	19.34	Poor — 7	20	...	...	...	Not done	...	...	...
17	North Akaskenaree	7 Top	27.56	19.64	Poor — 7	20	...	...	...	Not done	...	...	...
NAWAGARH AREA													
1	East Benedih	7 (sec. 4)	16.45	21.24	Semi — 12	30 to 50	30	40	50	20	20	20	40
2	Central Kenduadih	"	21.56	20.20	Semi — 9	10	20	10	20	N	N	10	10
3	South Barora	"	20.12	19.64	Semi — 9	10 to 20	20	10	10	N	10	10	10
4	Pure Ganespur	"	21.36	18.64	Semi — 9	10	10	10	20	N	N	10	10
5	Khas Kenduadih	9 Bot.	29.60	17.74	Semi — 9	20	...	...	...	Not done	...	...	...
6	Selected Phularitand	9 Bot.	26.92	19.44	Semi — 9	20	...	...	...	Not done	...	...	...
7	Berwabera	8	23.14	20.12	Semi — 9	10 to 20	10	10	20	N	10	N	N
8	West Phularitand	7 (sec. 4)	22.96	19.34	Semi — 9	10	10	10	10	N	N	N	10
9	Khas Kenduadih	9	27.60	19.20	Poor — 7	20	...	...	...	Not done	...	...	...
10	Khas Joyramdih	9	24.62	18.70	Poor — 6	10	10	10	20	N	N	N	...

\* Figures indicate maximum percentage of test coals usable in blends to produce satisfactory coke. — See Table No. 2d for analysis of coking coals.  
N = Not even 10 per cent of the test coals was found usable.

TABLE No. 2c — SUMMARY OF RESULTS OF LABORATORY BLENDING TEST WITH JHARIA COALS — (continued)

SERIAL No.	COLLIERY	SEAM	PROX. ANALYSIS (DRY) %		COKING PROPERTIES & COKING INDEX	BLENDING TEST RESULTS WITH COKING COALS*							
			Ash	V.M.		LOW VOLATILE COALS			MEDIUM VOLATILE COALS			HIGH VOLATILE COALS	
						Sijua	Choitodih	Malkera	Ramnagar	Chanch	W.Bokaro	Bhatdee	Murulidih
NUDKHURKEE KARMATAND AREA													
1	Pure Damuda	7 (1st & 2nd sec.)	21.85	18.64	Semi — 11	20	20	20	30	N	10	10	20
2	Pure Damuda	7 (4th sec.)	24.82	18.02	Semi — 10	10 to 20	20	10	20	N	10	10	20
3	Isabella	7 Special (4th sec.)	18.98	17.76	Semi — 10	30	20	30	30	10	20	20	50
4	Matigora	9	22.14	19.60	Semi — 9	20	20	20	10	N	10	N	10
5	Bokaro Jharia	9	22.42	18.78	Poor — 7	10	10	10	20	N	N	N	10
6	New Joyramdih	9	23.36	17.60	Poor — 4	10	10	N	10	N	10	N	N
7	Pure Damuda	7 (5th sec.)	23.84	15.60	Poor — 4	10	10	10	10	N	N	N	N
DHANSWAR DOBARI AREA													
1	Khas Jharia Dobari	9	24.32	20.00	Semi — 9	10	10	10	20	N	N	N	10
2	Dobari	7 & 8	24.56	19.64	Semi — 9	10	10	10	20	N	N	10	10
3	North Dobari	7 & 8	22.52	19.00	Semi — 9	10	10	10	20	N	N	N	10
4	Dhanswar North Bhuggutdih	5 (mid. sec.)	22.42	18.92	Semi — 9	10 to 20	10	10	20	10	10	10	10
5	Dhanswar	5 (3rd sec.)	21.78	19.40	Semi — 9	10	10	10	20	N	N	N	10
6	Dhanswar	5 (2nd sec.)	21.90	19.16	Semi — 8	10	10	10	10	N	N	N	N
7	Haripur	1	19.50	19.30	Semi — 8	20 to 30	20	30	30	10	20	10	40
8	Dhanswar North Bhuggutdih	5 (bot. sec.)	23.90	18.40	Poor — 7	10	N	N	20	N	N	N	N
9	Dhanswar	5 (bot. sec.)	23.50	19.06	Poor — 6	10	10	10	20	N	N	N	10
10	East Godhur	5 (top sec.)	21.82	17.48	Poor — 5	10	N	N	20	N	N	N	N
TISRA JENAGORA AREA													
1	Kalithan Jenagora	9	20.46	24.02	Fair — 13	20	20	10	30	10	N	10	20
2	Tisra	8	23.02	21.74	Semi — 0	10	10	20	20	10	N	10	10
3	Lower Upper Jharia	8	24.34	20.14	Semi — 10	10	10	10	20	N	N	N	10
4	Indian Jharia	8	22.72	21.16	Semi — 10	10	10	10	20	10	N	10	10
5	Tisra	8	24.60	21.40	Semi — 9	10	10	10	20	N	N	N	10
6	New Jenagora	9	23.94	21.52	Semi — 9	10	10	10	20	10	N	N	10
7	Tisra	7	23.74	24.72	Semi — 9	10	10	N	20	N	N	N	N
8	Lower Upper Jharia	7	21.94	20.64	Semi — 9	10	10	10	20	N	N	N	N

\* Figures indicate maximum percentage of test coals usable in blends to produce satisfactory coke. — See Table No. 2d for analysis of coking coals.  
N = Not even 10 per cent of the test coals was found usable.

**TABLE No. 2d — PROXIMATE ANALYSIS OF COKING COALS USED FOR LABORATORY BLENDING TESTS WITH BELOW 10 SEAM COALS FROM THE JHARIA FIELD**

SERIAL No.	COLLIERY	SEAM	ASH	V.M.	F.C.	C.I.	REMARKS
LOW VOLATILE COKING COALS							
1	Sijua ...	16	16.64	23.36	55.00	17	Sijua 16 seam in general gave better results than coals from other seams of the same colliery.
2	do ...	16	18.80	26.32	56.88	15	
3	do ...	14	17.24	24.56	58.20	15	
4	do ...	14	13.88	23.04	63.08	15	
5	do ...	12	13.32	28.56	58.12	15	
6	do ...	12	16.07	23.02	60.91	16	
7	do ...	15	14.60	25.30	60.10	15	
8	Choitodih ...	13, 14 & 15	15.40	24.86	59.68	16	
9	do ...	do	19.14	24.76	56.20	15	
10	Malkera ...	do	17.04	25.46	57.50	16	
MEDIUM VOLATILE COKING COALS							
11	Ramnagar ...	Laikdih bottom	12.76	30.04	57.20	16	West Bokaro 9 seam gave very poor results and therefore was not used in most of the tests.
12	do ...	do	13.76	29.65	56.59	16	
13	Chanch ...	Chanch	15.70	31.24	53.08	16	
14	West Bokaro ...	9	17.40	26.20	56.40	13	
15	do ...	10	13.15	31.18	55.67	15	
HIGH VOLATILE COKING COALS							
16	Murulidih ...	Mohuda bottom	12.76	35.56	51.68	16	
17	Bhatdee ...	do	13.14	35.08	51.78	16	

**TABLE No. 2e — A LIST OF SELECTED "BELOW 10 SEAM" COALS FROM THE JHARIA FIELD WARRANTING WASHABILITY STUDY**

SERIAL No.	COLLIERY	SEAM & SECTION	AREA	PROX. ANALYSIS (DRY) %			Caking Index
				Ash	Vol. Matter	Fixed Carbon	
ASH CONTENT BELOW 20%							
1	East Basseria ...	7	Kusunda	10.48	19.36	71.16	14
2	East Salanpur ...	9 Special	Katrasgarh	18.58	20.90	60.52	12
3	Khas Govindapur ...	7 Special	do	19.40	20.22	60.38	13
4	West Katras	7 Middle	do	18.66	20.02	61.32	12
5	East Benedih ...	7 sec. 4	Nawagarh	16.45	21.24	62.31	12
6	Isabella ...	7 Special	Nudkharkee	18.98	17.76	63.26	10
7	Haripur ...	1 sec. 4	Dhanswar Dobari Jharia	19.50	19.30	71.20	8
ASH CONTENT OVER 20% & BELOW 25%							
8	Central Salanpur ...	9 Bottom	Katrasgarh	22.24	20.10	57.66	12
9	Central Salanpur ...	9	do	22.48	20.00	57.52	11
10	Khas Methadih ...	9	do	24.10	20.34	55.56	11
11	North Akaskenaree ...	7 Middle	do	24.86	19.64	55.50	11
12	North Tetulia ...	5	do	22.04	19.46	58.50	11
13	North Salanpur ...	9	do	22.40	20.12	57.48	10
14	Central Bansjora Khas	8	Teetulmari Chandore	20.04	22.02	57.94	14
15	Pandedih ...	8	do	21.84	20.36	57.80	13
16	Pure Selected Angarpatra	8	do	24.40	20.24	55.36	11
17	Khas Pandedih ...	8	do	23.84	19.20	56.96	10
18	Central Bansjora	8	do	24.04	18.52	57.44	10
19	Central Bansjora	7	do	24.32	19.34	56.34	10
20	Nichitpur ...	Special	Kusunda	21.72	19.00	59.28	13
21	Sendra Bansjora	9 Top	do	22.56	18.64	58.80	12
22	Central Gararia ...	9 Top	do	21.98	20.00	58.02	12
23	Gararia ...	9 Special	do	22.02	19.46	58.52	10
24	Pure Damuda ...	7 1st & 2nd	Nudkharkee-Karnatand	21.66	18.64	59.50	11
25	Pure Damuda ...	7 4th	do	24.82	18.02	57.16	10
26	Kalithan Jenagora ...	9	Tisra Jenagora	20.46	24.02	55.52	13
27	Tisra ...	8	do	23.02	21.74	55.24	10
28	Lower Upper Jharia ...	8	do	24.34	20.14	55.52	10
29	Indian Jharia ...	8	do	22.72	21.16	56.12	10
ASH CONTENT OVER 25% & BELOW 30%							
30	Sendra Bansjora	Special	Kusunda	25.98	18.64	55.38	12
31	Gararia ...	9 Top & bot.	do	27.10	18.52	54.38	10
32	North Salanpur ...	9 Bottom	Katrasgarh	26.00	19.57	54.43	13
33	Golakdih ...	9	Tisra Jenagora	25.20	20.66	54.14	11

TABLE No. 3a — PARTICULARS OF SAMPLES OF COALS FROM THE  
RANIGANJ COALFIELD

SERIAL No.	GRADE	COLLIERY	KIND OF COAL	SEAM
1	...	Perbelia	Rubble	Dishergarh
2	...	"	"	"
3	...	"	"	"
4	...	Seetalpur	"	"
5	...	"	"	"
6	...	Dishergarh	"	"
7	...	"	"	"
8	...	Sodepur	"	"
9	...	"	"	"
10	...	Dhemo Main	"	"
11	...	"	"	"
12	...	Mebhani	"	"
13	...	"	"	"
14	...	Bejdih	"	"
15	...	"	"	"
16	...	Bermundia	"	"
17	...	"	"	"
18	...	Saltore	"	"
19	...	"	"	"
20	...	Pondih	"	"
21	...	"	"	"
22	...	Banksimulla	"	Poniati
23	...	Jamuria	"	"
24	...	Sripur—Poniati	Slack	"
25	...	East Baraboni	"	"
26	...	South East Baraboni	"	"
27	...	Kbas Kajora	"	Kajora
28	...	"	"	Jambad Top
29	...	"	"	Jambad Bott.
30	Sel. A	Sripur	R/mine	Poniati
31	"	"	"	"
32	"	Banksimulla	"	Koithi
33	"	"	"	"
34	Sel. B	Adjai Second	"	Rana
35	"	Central Nandi	Steam	Taltore
36	Sel. A	Damra	R/mine	Ghusick
37	"	"	"	"
38	Sel. B	Chāpuikhas	"	Niga
39	"	Ghusick	Steam	Kusumdanga
40	"	"	"	"
41	"	Satpukuria	Steam	Satpukuria
42	Sel. A	Begonia	R/mine	Begonia
43	"	"	"	"
44	Sel. B	West Laikdih	"	Kharbari
45	Sel. A	Seetalpur	"	Sanctoria
46	"	"	"	"
47	Sel. B	Sanctoria	Steam	Hatnal
48	"	Patmohana	R/mine	Bharatchuk
49	"	Central Kajora	"	Kajora Lower
50	"	"	"	"
51	"	Kajora	"	Kajora Upper
52	Sel. B	Sanla Ramnagar	"	Sanla
53	"	"	"	"
54	"	Searsole	"	Egara
55	"	New Kenda	Steam	Kenda
56	"	Jote Janakikhas	R/mine	Chowkidanga
57	"	Toposi	"	Toposi
58	"	Satgram	Steam	Satgram
59	"	New Satgram	R/mine	Bogra
60	"	"	"	"
61	"	Korabad	"	Kasta
62	"	"	"	"
63	"	Badjna	"	Badjna
64	"	W. Jotedhemo	"	Bombabal
65	I	"	"	"
66	III-B	Raipura	"	Kalimati
67	Sel. B	Kuardih	"	Ghusick

TABLE No. 3b — RESULTS OF ANALYSIS OF COALS FROM THE RANIGANJ COALFIELD

SERIAL No.*	PROX. ANALYSIS			TOTAL SULPHUR %	PHOS. IN COAL %	CANKING INDEX	SWELLING TEST		FUSION RANGE OF ASH Deg. C.	COLOUR OF ASH	SOFTENING POINT Deg. C.	ULTIMATE ANALYSIS ON DRY BASIS				CALORIFIC VALUE IN B.Th.U./lb.		
	MOISTURE	DRY %					Koppers	Nedelmann's Pressure lb./sq. in.				Carbon %	Hydrogen %	Nitrogen %	Oxygen %			
		Ash	Volatile matter	Fixed Carbon														
1	...	11.66	38.44	49.90	0.274	0.094	12	Harmless	...	1200 — 1230	...	...	...	...	...	12,678		
2	...	10.58	38.92	50.50	0.286	0.092	13	"	...	1210 — 1240	...	...	...	...	...	12,870		
3	3.5	14.28	38.10	47.62	...	...	...	"	...	...	...	...	...	...	...	...		
4	...	11.00	38.66	50.34	0.291	0.080	13	"	...	1180 — 1210	...	...	...	...	...	12,780		
5	3.1	10.54	39.22	50.24	...	...	...	"	...	...	...	...	...	...	...	...		
6	...	11.24	38.08	50.58	0.310	0.090	13	"	...	1160 — 1200	...	...	...	...	...	12,734		
7	2.9	11.84	38.52	49.64	...	...	...	"	...	...	...	...	...	...	...	...		
8	...	15.16	37.09	47.75	0.320	0.088	11	"	...	1215 — 1240	...	...	...	...	...	12,315		
9	3.7	12.32	37.78	49.90	...	...	...	"	...	...	...	...	...	...	...	...		
10	...	12.74	38.40	48.86	0.302	0.070	12	"	...	1220 — 1250	...	...	...	...	...	12,515		
11	3.4	14.54	38.12	47.34	...	...	...	"	...	...	...	...	...	...	...	...		
12	...	12.20	38.58	49.22	0.270	0.068	13	"	...	1190 — 1230	...	...	...	...	...	12,582		
13	3.2	12.14	38.56	49.30	...	...	...	"	...	...	...	...	...	...	...	...		
14	...	12.08	38.84	49.08	0.256	0.056	12	"	...	1210 — 1230	...	...	...	...	...	12,610		
15	3.4	12.12	38.44	49.44	...	...	...	"	...	...	...	...	...	...	...	...		
16	...	10.90	39.56	49.54	0.264	0.068	13	"	...	1180 — 1220	...	...	...	...	...	12,825		
17	3.3	13.34	37.92	48.74	...	...	...	"	...	...	...	...	...	...	...	...		
18	...	11.38	39.14	49.48	0.275	0.090	12	"	...	1200 — 1240	...	...	...	...	...	12,710		
19	2.8	12.14	38.12	49.74	...	...	...	"	...	...	...	...	...	...	...	...		
20	...	10.62	39.12	50.26	0.260	0.070	12	"	...	1190 — 1220	...	...	...	...	...	12,846		
21	3.0	11.96	38.46	49.58	...	...	...	"	...	...	...	...	...	...	...	...		
22	3.1	10.81	38.84	50.35	0.224	0.110	12	"	...	...	...	...	...	...	...	...		
23	4.2	13.80	37.76	48.44	0.380	0.156	11	"	...	...	...	...	...	...	...	...		
24	3.3	11.36	36.98	51.66	0.234	0.144	12	"	...	...	...	...	...	...	...	...		
25	2.8	15.65	36.30	48.05	0.430	0.128	10	"	...	...	...	...	...	...	...	...		
26	4.8	12.18	38.16	49.66	0.446	0.138	10	"	...	...	...	...	...	...	...	...		
27	6.8	11.20	41.90	46.90	0.296	0.048	2	"	...	1290 — 1330	Buff	...	...	...	...	11,930		
28	5.8	12.02	40.54	47.44	0.302	0.059	2	"	...	1280 — 1320	Pink	...	...	...	...	11,830		
29	5.1	15.44	38.68	45.88	0.357	0.038	2	"	...	1240 — 1280	Buff	...	...	...	...	11,380		
30	2.6	14.76	33.42	51.82	0.398	0.236	9	"	...	1.66	1140 — 1170	Brown	384	67.46	4.58	1.67	11.13	...
31	2.9	12.26	37.16	50.58	0.364	0.168	11	"	...	0.464	1250 — 1280	Reddish brown	...	66.70	4.82	1.51	14.35	...
32	3.8	17.16	34.26	48.58	0.422	0.156	7	"	...	0.39	1250 — 1280	do	340	65.09	4.25	1.60	11.48	...
33	3.5	16.06	33.54	50.40	0.306	0.114	5	"	...	0.232	1250 — 1280	do	...	64.71	5.09	1.55	12.28	...
34	4.8	16.50	35.38	48.12	0.373	0.120	5	"	...	0.37	1250 — 1320	do	...	66.04	4.88	1.79	10.47	...

\* Refer to corresponding serial No. in Table No. 3a.

N.C. = Non-coking.

N.P. = No pressure developed.



TABLE No. 3b — RESULTS OF ANALYSIS OF COALS FROM THE RANIGANJ COALFIELD — (continued)

SERIAL No.*	PROX. ANALYSIS				TOTAL SULPHUR %	PHOS. IN COAL %	CAKING INDEX	SWELLING TEST		FUSION RANGE OF ASH Deg. C.	COLOUR OF ASH	SOFTENING POINT Deg. C.	ULTIMATE ANALYSIS ON DRY BASIS				CALORIFIC VALUE IN B.Th.U./lb.
	MOISTURE %	DRY %						Koppers	Nedelmann's Pressure lb./sq. in.				Carbon %	Hydrogen %	Nitrogen %	Oxygen %	
35	5.55	16.67	30.60	52.73	0.404	0.140	6	Harmless	0.33	1220—1290	Cream	...	...	...	1.50	...	...
36	3.5	15.58	35.22	49.20	0.307	0.118	6	"	0.39	1230—1260	Brick-red	353	63.48	4.18	1.58	14.87	...
37	4.0	15.04	37.12	47.84	0.255	0.124	6	"	0.12	1240—1260	Brown	...	65.14	5.03	1.81	12.74	...
38	8.6	16.20	34.94	48.86	0.357	0.083	6	"	N.P.	1290—1330	do	...	60.56	4.61	1.47	16.80	...
39	4.4	16.08	34.34	49.58	0.401	0.047	6	"	0.38	...	...	373	65.65	4.78	1.54	11.55	...
40	4.9	19.20	33.12	47.68	0.275	0.040	4	"	0.58	1340—1400	Reddish-brown	...	61.86	4.54	1.48	12.65	...
41	4.8	17.22	34.14	48.64	0.351	0.088	6	"	N.P.	1280—1330	Cream	...	...	...	1.80	...	...
42	2.4	13.30	29.06	57.64	0.408	0.100	13	"	0.35	1390—1430	Reddish-brown	...	...	...	1.76	...	...
43	1.0	14.20	28.07	57.73	0.750	0.060	13	"	0.73	...	...	...	...	...	...	...	...
44	1.8	25.53	27.71	46.76	0.408	0.044	7	"	...	1380—1420	White	356	60.00	4.43	1.15	8.48	...
45	1.8	14.52	34.04	51.44	0.324	0.088	12	"	0.97	...	...	372	68.11	4.70	1.71	10.64	...
46	2.05	15.08	34.64	50.28	0.320	0.090	15	"	1.08	...	...	...	...	...	...	...	...
47	1.50	19.96	32.28	47.76	0.387	0.074	4	"	...	...	...	390	62.79	4.54	1.73	10.59	...
48	2.8	14.06	34.64	51.30	0.441	0.168	4	"	1.70	1220—1250	Light brown	386	69.31	4.81	1.78	9.50	...
49	5.6	12.70	36.48	50.82	0.337	0.059	N.C.	"	N.P.	...	...	...	65.98	5.15	1.39	14.44	...
50	6.8	11.98	36.24	51.78	0.324	0.052	...	"	...	1390—1420	Reddish-brown	...	...	...	1.70	...	...
51	5.4	12.84	36.86	50.30	0.322	0.065	...	"	N.P.	...	...	...	67.97	5.25	1.50	12.12	...
52	9.5	14.68	32.64	52.68	0.442	0.086	3	"	...	...	...	415	64.22	4.37	1.79	14.52	...
53	10.0	13.38	34.30	52.32	0.468	0.052	N.C.	"	...	1300—1330	Cream	...	...	...	1.74	...	...
54	4.5	14.24	37.04	48.72	0.289	0.064	4	"	N.P.	...	...	393.5	66.15	5.05	1.34	12.93	...
55	8.8	15.80	33.02	51.18	0.470	0.070	6	"	0.19	1280—1360	Light brown	...	...	...	1.54	...	...
56	5.8	16.43	36.63	46.94	0.450	0.179	7	"	0.23	1200—1250	Grey	...	...	...	...	...	...
57	5.1	15.64	33.64	50.72	0.436	0.152	6	"	0.95	1300—1330	Deep cream	330	64.21	4.61	1.64	13.46	...
58	3.6	16.28	33.75	49.97	0.291	0.048	3	"	0.35	1300—1340	do	395	65.53	4.92	1.64	11.34	...
59	4.2	17.62	34.30	48.08	0.426	0.028	7	"	0.31	1350—1380	Cream	370	63.10	4.85	1.60	12.40	...
60	5.3	15.67	31.16	53.17	0.530	0.070	6	"	0.12	1250—1300	Brick-red	...	...	...	1.64	...	...
61	2.4	19.70	31.94	48.96	0.670	0.028	6	"	0.35	1360—1420	Grey	408	63.64	4.53	1.42	10.05	...
62	4.2	22.50	28.83	48.67	0.800	0.173	9	"	0.15	1240—1320	Brown	...	...	...	...	...	...
63	1.84	16.66	23.72	59.62	0.426	0.267	10	"	0.54	1340—1390	White	...	...	...	1.25	...	...
64	5.1	24.46	31.26	44.28	0.285	0.095	N.C.	"	N.P.	...	...	...	58.48	4.44	1.34	11.00	...
65	9.4	19.67	32.96	47.27	0.570	0.050	N.C.	"	...	1370—1410	Reddish brown	...	...	...	1.45	...	...
66	3.0	37.84	19.46	42.68	0.225	traces	4	"	"	...	...	351	52.55	3.58	1.05	4.76	...
67	4.0	14.00	37.20	48.80	0.350	0.184	4	"	0.078	1210—1280	...	...	...	...	...	...	...

\* Refer to corresponding serial No. in Table No. 3a.

N.C. = Non-coking

N.P. = No pressure developed.

TABLE No. 3c — RESULTS OF SCREEN ANALYSIS OF RANIGANJ COALS

Sl. No.	COLLIERY	SEAM	OVER 2" SCREEN			BETWEEN 2" & 1"			BETWEEN 1" & 1/2"			BETWEEN 1/2" & 1/4"			BETWEEN 1/4" & 1/8"			BETWEEN 1/8" & 30 MESH			BETWEEN 30 & 60 MESH			BELOW 60 MESH		
			Wt.	Ash	CI	Wt.	Ash	CI	Wt.	Ash	CI	Wt.	Ash	CI	Wt.	Ash	CI	Wt.	Ash	CI	Wt.	Ash	CI	Wt.	Ash	CI
			%	%		%	%		%	%		%	%		%	%		%	%		%	%		%	%	
1	Sripur	Poniati	14.50	10.30		14.50	14.70		16.00	22.10		18.50	15.80		12.00	14.40		15.00	13.80		2.50	15.22		7.00	22.58	
2	do	do	38.50	11.58		41.00	17.84		15.50	11.00		2.25	12.76		0.75	11.50		1.25	11.20		0.25	10.14		0.50	17.18	
3	Banksimulla	Koithi	15.00	20.24		16.66	15.70		17.07	18.40		11.66	17.60		10.83	14.86		14.56	11.28		2.08	11.20		12.14	18.40	
4	do	do	24.00	14.50		26.00	16.88		13.00	16.74		9.50	17.62		8.00	16.32		2.50	13.00		2.50	15.28		4.50	22.04	
5	Adaj Second	Rana	20.00	19.26		20.50	18.04		15.00	19.56		11.50	16.60		8.00	14.72		9.50	13.04		2.00	13.54		4.50	18.54	
6	Central Nandi	Taltore	42.00	16.56	5	33.00	16.28	5	8.00	18.40	5	4.50	15.64	6	4.00	13.00	6	5.00	11.40	6	1.50	17.14	5	2.00	23.64	2
7	Damra	Ghusick	40.00	17.20		30.00	19.70		9.00	17.24		5.00	15.00		3.00	12.60		2.00	8.62		1.00	8.06		1.00	14.26	
8	do	do	42.12	14.00		24.73	15.46		12.73	14.56		7.34	13.58		4.31	12.64		5.55	9.78		1.07	11.08		2.15	15.20	
9	Chapuikhas	Niga	14.00	13.58		26.00	11.80		24.50	15.94		14.00	15.02		7.50	15.76		9.50	12.04		1.50	13.40		3.00	10.84	
10	Ghusick	Kusundanga	28.50	18.10		48.00	16.00		12.50	17.00		5.00	16.80		2.50	13.88		2.50	10.74		0.50	10.20		0.50	14.60	
11	do	do	45.00	17.20		25.00	17.34		15.00	18.66		6.00	17.48		4.00	15.84		3.50	12.50		0.50	13.78		0.50	10.04	
12	Satpukuria	Satpukuria	55.00	15.92		27.00	23.50		8.00	18.80		3.00	15.50		2.00	15.00		3.00	10.42		0.50	10.52		1.50	17.30	
13	Begonia	Begonia	29.50	12.09		25.50	15.10		21.00	14.22		10.00	13.32		5.00	12.00		6.25	11.60		1.00	10.45		1.75	17.02	
14	do	do	26.00	12.16	12	24.00	17.02	12	19.00	15.00	12	14.00	14.08	13	7.50	12.08	13	6.00	11.78	14	2.00	14.76	10	1.00	17.08	8
15	West Laikdih	Kharbari	36.00	22.10		41.00	21.98		17.00	21.70		4.00	15.74		1.25	22.80		0.25	11.20		0.25	17.14		0.25	10.40	
16	Seetalpur	Sanctoria	8.00	13.00		17.50	14.20		22.50	15.30		18.50	14.00		10.50	8.98		13.50	8.90		2.50	20.28		7.00	28.00	
17	do	do	15.00	15.08	14	19.00	15.50	14	15.25	15.22	14	14.25	12.40	15	11.50	12.20	15	14.50	12.84	15	5.25	23.46	9	5.25	27.08	7
18	Sanctoria	Hatnal	0.50	22.80		48.50	20.70		24.00	20.94		8.50	19.20		4.00	16.44		4.00	14.36		1.00	13.20		0.50	17.42	
19	Patmohana	Bharatchuck	32.00	18.40		23.50	17.20		9.50	16.00		8.00	18.28		7.00	4.40		11.50	11.92		2.50	12.96		6.00	22.10	
20	Central Kajora	Kajora Lower	35.00	12.12		45.00	14.20		14.50	11.48		3.50	10.80		1.00	9.42		0.50	4.66		0.25	6.84		0.25	12.18	
21	do	do	22.50	11.52		17.00	12.84		22.00	11.88		15.50	11.60		10.50	9.00		8.50	8.50		1.50	10.20		4.50	15.16	
22	Kajora	Kajora Upper	6.00	16.10		28.50	14.10		25.50	13.62		18.00	13.30		10.00	9.54		9.00	8.70		1.00	9.70		2.00	17.20	
23	Samla Ramnagar	Samla	49.00	14.80		21.50	15.40		8.50	15.84		6.00	15.10		6.00	11.32		7.50	10.70		0.50	13.20		1.00	19.56	
24	do	do	25.75	13.48		13.50	13.00		15.50	14.56		17.75	13.34		11.50	10.50		6.75	12.12		1.50	14.88		7.75	22.00	
25	Searsale	Egara	30.00	12.80		44.00	13.40		13.00	14.24		6.00	12.82		2.50	9.90		2.50	9.20		0.50	9.68		1.50	16.00	
26	New Kenda	Kenda	26.75	16.10	4	28.50	17.58	5	17.50	17.42	4	11.75	13.02	6	7.00	10.48	6	5.75	11.10	6	1.00	13.60	7	1.75	20.68	4
27	Jote Janaki Khas	Chowkidanga	44.00	14.34	5	38.00	19.08	5	11.50	21.14	5	3.00	16.06	6	1.50	15.00	7	1.00	11.20	7	0.50	14.38	5	0.50	22.36	4
28	Toposi	Toposi	40.00	13.60		34.00	16.56		11.00	16.20		5.50	15.70		3.50	8.04		5.00	10.88		0.50	10.88		0.50	18.60	
29	Satgram	Satgram	43.50	17.30		31.50	17.24		14.00	16.60		5.00	14.10		2.50	11.40		2.50	9.22		0.50	12.12		0.50	19.10	
30	New Satgram	Bogra	18.50	19.40		34.00	18.40		18.00	22.50		12.00	20.28		10.00	15.18		6.00	14.48		0.50	17.80		1.00	23.00	
31	do	do	23.00	18.70	6	32.00	20.36	6	14.50	19.68	6	11.40	18.20	7	9.00	13.96	7	6.00	12.04	8	1.00	13.98	6	3.00	21.62	
32	Korabad	Kasta	17.50	20.60		51.00	21.66		14.50	22.46		7.50	19.40		3.50	17.80		4.00	17.64		0.50	17.06		1.50	24.20	
33	do	do	25.00	22.80	6	22.50	23.68	6	14.00	18.98	7	11.00	22.34	8	6.00	19.79	9	10.00	19.96	10	2.00	23.46	7	8.50	31.83	2
34	Badjna	Badjna	34.00	15.88	8	20.00	14.26	8	22.50	16.56	8	11.50	17.78	10	3.00	16.60	11	2.50	14.98	12	1.50	15.34	10	5.00	21.23	8
35	West Jotedhemo	Bombabhal	14.00	22.08	NC	26.00	28.92	NC	19.50	28.20	NC	10.00	25.16	NC	8.00	18.04	NC	2.50	13.20	NC	2.00	19.40	NC	8.00	29.80	NC
36	do	do	35.00	21.16		14.00	23.44		15.00	21.76		12.00	18.16		9.00	13.24		1.00	15.22		1.00	14.38		3.00	36.34	
37	Rajpura	Kalimati	59.00	20.60		21.00	30.20		11.00	34.50		3.00	35.90		0.50	33.00		0.50	30.10		0.50	30.70		4.50	37.00	
38	Kuardih	Ghusick	31.00	5.46	5	21.00	13.00	5	25.50	13.78	6	12.50	14.36	5	5.00	11.54	5	4.00	9.08	5	0.50	11.78	3	0.50	24.84	

CI = Caking Index.

NC = Non-coking

TABLE No. 3d — SUMMARY OF RESULTS OF LABORATORY BLENDING TESTS WITH RANIGANJ COALS

SERIAL No.	COLLIERY	SEAM	PROXIMATE ANALYSIS ( DRY ) %		COKING PROPERTIES & CAKING INDEX	BLENDING TEST RESULTS WITH COKING COALS*						
			Ash	Volatile matter		Tata's Mixed Charging	Low Volatile					
						Sijua	Choitodih	Malkera				
1. DISHERGARH & PONIATI SEAMS												
1	Seetalpur	...	...	Dishergarh	...	10.54 to 11.00	30.22 to 38.66	Fair coking — 13	60	60	50	60
2	Dishergarh	...	...	do	...	11.24 to 11.84	38.08 to 38.52	" — 13	40	50—60	40	40
3	Methani	...	...	do	...	12.14 to 12.20	38.56 to 38.58	" — 13	40	50—60	40	50
4	Bermunda	...	...	do	...	10.90 to 13.34	30.56 to 37.02	" — 13	60	60	60	60
5	Parbelia	...	...	do	...	10.58 to 14.28	38.02 to 38.10	" — 13	60	60	60	60
6	Dhemo Main	...	...	do	...	12.74 to 14.54	38.40 to 38.12	Semi-coking — 12	50	50	40	40
7	Bejdih	...	...	do	...	12.08 to 12.12	38.84 to 38.44	" — 12	50	50—60	50	50
8	Saltore	...	...	do	...	11.38 to 12.14	30.14 to 38.12	" — 12	50	50—60	60	60
9	Pondih	...	...	do	...	10.62 to 11.06	30.12 to 38.46	" — 12	50	50—60	60	60
10	Sodepur	...	...	do	...	15.16 to 12.32	37.09 to 37.78	" — 11	Less than 40	40 or below	...	Below 40
11	Banksimulla	...	...	Poniati	...	10.81	38.84	" — 12	30	30—40	30	30
12	Sripur Poniati †	...	...	do	...	11.36 to 14.76	33.42 to 37.16	" — 9/12	30	20—40	40	30
13	Jamuria	...	...	do	...	13.80	37.76	" — 11	20	20—30	30	20
14	East Baraboni	...	...	do	...	15.05	36.30	" — 10	20	20	20	20
15	South-east Baraboni	...	...	do	...	12.18	33.16	" — 10	20	20	20	20

\* The figures indicate the maximum percentage of the test coals usable in blends with coking coals to yield satisfactory coke. — See Table No. 3e for the analysis of coking coals.

† Also with medium volatile Laikdih 30 per cent.

TABLE No. 3d — SUMMARY OF RESULTS OF LABORATORY BLENDING TESTS WITH RANIGANJ COALS — (continued)

SERIAL No.	COLLIERY	SEAM	PROXIMATE ANALYSIS (DRY) %		COKING PROPERTIES & COKING INDEX	BLENDING TESTS WITH COKING COALS*				
			Ash	Volatile matter		Tata's M.C.	Low vol.	Med. vol.	High vol.	
2. SEAMS OTHER THAN DISHERGARH & PONIATI										
16	Seetalpur	...	Sanctoria	14.52 to 15.08	34.04 to 34.64	Semi-coking — 12	30—40(a)	30(a)	40—50(a)	30—40(a)
17	Badjan	...	Badjna	16.66	23.72	" — 10	20	20	30	20
18	Banksimulla	...	Kaithi	17.16 to 16.08	34.26 to 33.54	Poor coking — 7.6	10	10	20—30	20
19	West Laikdih	...	Kharbari	25.53	27.71	" — 7	20	20	30	10
20	Jote Jankikhas	...	Chowkidanga	16.43	36.63	" — 7	20	10	30	20
21	New Satgram	...	Bogra	17.62 to 15.67	34.30 to 31.16	" — 7.6	20	20(b)	20—30(b)	20
22	Korabad	...	Kasta	19.70 to 22.50	28.83 to 31.94	" — 6	10	10	20	...
23	Damra	...	Ghusick	15.58 to 15.04	35.22 to 37.12	" — 6	10—20	10—20(c)	20—30	10—20
24	Satpukuria	...	Satpukuria	17.22	34.14	" — 6	10	10	20—30	10
25	New Kenda	...	Kenda	15.80	33.02	" — 6	10—20	10	20—30	10
26	Toposi	...	Toposi	15.64	33.64	" — 6	20	20	30	20
27	Central Nandi	...	Taltore	16.07	30.60	" — 6	10	10	30	20
28	Chapuikhas	...	Niga	16.20	34.94	" — 6	20	20	30	10(b)
29	Ghusick	...	Kusundanga	16.08 to 10.20	34.34 to 33.12	" — 4/6	10	10	20—30	10
30	Kuardih	...	Ghusick	14.00	37.20	" — 5	10—20	10—20	20—30	10—20
31	Adjal Second	...	Rana	16.50	35.38	" — 5	10	10(d)	30	20
32	Sanctoria	...	Hatnal	19.06	32.28	" — 4	20	20	30	20
33	Patmohana	...	Bharatchuck	14.06	34.64	" — 4	20	10(a)	30	20
34	Searsole	...	Egara	14.24	37.04	" — 4	10	10	30	20
35	Rajpura	...	Kalimati	No blending test done due to high ash content.						
36	Samla Ramnagar	...	Samla	14.68	32.64	" — 3	10	10(d)	30	10
37	Satgram	...	Satgram	16.28	33.75	" — 3	20	10—20	30	20
38	West Jotedhemo	...	Bombahal	24.46 to 19.67	31.26 to 32.06	Non-coking	20	10	30	20
39	Central Kajora	...	Kajora Lower	11.98 to 12.70	36.24 to 36.48	"	10	20(d)	20—30	20
40	Kajora	...	Kajora Upper	12.84	36.86	"	10	10	30	10
41	Khas Kajora	...	Kajora	11.20	41.90	"	Not done	10—20	10	10
42	Khas Kajora	...	Jambad Top	12.02	40.54	"	"	10—20	10	10
43	Khas Kajora	...	Jambad Bottom	15.44	38.68	"	"	10—20	10	10

(a) Possibility of utilizing 30 per cent of the coal confirmed by semi-large-scale test. See Table No. 3f. — (b) Possibility of utilizing 15 per cent of the coal with 85 per cent of Sijua mixed seam and 20 per cent of the coal with 80 per cent of the Laikdih coal confirmed by semi-large-scale test. See Table 3f. — (c) Possibility of utilizing 20 per cent of the coal confirmed by semi-large-scale test. See Table 3f. — (d) Possibility of utilizing 15 per cent of the coal confirmed by semi-large-scale test. See Table 3f.

\* The figures indicate the maximum percentage of the test coals usable in blends with coking coals to yield satisfactory coke. See Table No. 3e for analysis of coking coals.

**TABLE No. 3e — PROXIMATE ANALYSIS OF COKING COALS USED FOR LABORATORY BLENDING TESTS  
WITH RANIGANJ COALS**

SERIAL No.	COLLIERY	SEAM	PROX. ANALYSIS (DRY) %			COKING INDEX	
			Ash	Volatile matter	Fixed Carbon		
1	Mixed Charging Coal	... ..	16.92	25.48	57.60	16	Used with Poniati seam coals.
2	" " "	... ..	18.00	25.34	56.66	16	Used with Dishergarh seam coals.
3	" " "	... ..	17.60	25.27	57.13	14/15	Used with Raniganj coals other than Dishergarh & Poniati seams.
4	Sijua ...	... 12	16.18	23.08	60.74	15	Used with Raniganj coals other than Dishergarh & Poniati seams.
5	"	... 12	13.32	29.56	58.12	15	Used with Kajora, Jambad Top and Bottom seam coals.
6	"	... 14	17.24	24.56	58.20	15	Used with Kajora, Jambad Top and Bottom seam coals.
7	"	... 14	14.22	25.10	60.68	16	Used with Dishergarh seam coals.
8	"	... 14	15.80	22.88	61.32	16	Used with Poniati seam coals.
9	"	... 16	16.64	28.36	55.00	17	Used with Kajora, Jambad Top and Bottom seam coals.
10	"	... 16	18.80	27.54	53.66	17	Used with Dishergarh seam coals.
11	"	... 16	17.48	26.40	56.12	16	Used with Poniati seam coals.
12	"	... 12, 13, 14, 15	15.76	22.14	62.10	14/15	Used with Raniganj coals other than Dishergarh & Poniati seams.
13	Malkera	... 13, 14, 15	17.04	25.46	57.50	16	Used with Kajora, Jambad Top and Bottom seams.
14	"	... 13, 14, 15	16.12	24.72	59.16	16	Used with Dishergarh seam coals.
15	"	... 13, 14, 15	15.65	24.78	59.57	16	Used with Poniati seam coals.
16	Choitodih	... 13, 14, 15	15.46	24.86	59.68	16	Used with Kajora, Jambad Top and Bottom seams.
17	"	... 13, 14, 15	14.90	24.78	60.32	16	Used with Dishergarh seam coals.
18	"	... 13, 14, 15	14.60	26.02	59.38	16	Used with Poniati Seam coals.
19	West Bokaro	... 9	17.40	26.20	56.40	13	Used with Khas Kajora coals.
20	"	... 10	13.15	31.18	55.67	15	Used with Khas Kajora coals.
21	Ramnagar	... Laikdih Bottom	12.76	30.04	57.20	16	Used with Khas Kajora coals.
22	Laikdih	... Laikdih Deep	13.89	27.05	59.06	16/17	Used with Raniganj coals other than Dishergarh & Poniati seams.
23	Chanch	... Chanch	15.70	31.24	53.06	16	Used with Kajora, Jambad Top and Bottom seams.
24	Murulidih	... Mohuda Bottom	15.40	35.46	49.14	15	Used with Kajora, Jambad Top and Bottom seams.
25	"	... " "	13.75	34.65	51.69	15	Used with Raniganj coals other than Dishergarh & Poniati seams.
26	Bhatdee	... " "	13.14	35.08	51.78	16	Used with Kajora, Jambad Top and Bottom seams.

TABLE No. 3f — SUMMARY OF RESULTS OF SEMI-LARGE-SCALE TESTS CARRIED OUT WITH RANIGANJ COALS (THOSE GIVING SATISFACTORY OR FAIRLY SATISFACTORY RESULTS) ALONG WITH RESULTS OF ALL LARGE-SCALE FULL OVEN TESTS

SL. No.	EXPT. No.	CHARGING BLEND	PERCENTAGE OF BLEND	PROX. ANALYSIS OF THE BLEND — %			CAKING INDEX	PROX. ANALYSIS OF COKE ( DRY )		PHYSICAL TEST OF COKE			QUALITY OF COKE	POROSITY %
				Moisture	Ash	Vol. matter		Ash	Vol. matter	Shatter Test Index 2"/14"	Haven's Test Stability on 1"	Breslau's Test Total on 40 mm.		
1	R-24*	<i>Sripur</i>												
		Sijua 12 Seam ...	15/85	1.00	15.78	24.30	13	21.30	0.08	78/02	61.36	84.00	Hard	46.76
2	R-45	<i>Sripur</i>												
		Sijua Mixed Seam ...	20/80	5.50	14.76	25.96	13	10.30	0.06	77/01	50.50	84.00	Hard	50.76
3	R-47(a)	<i>Sripur</i>												
		Laikdih ...	20/80	2.25	13.82	30.28	14	18.42	1.09	76/02	50.00	78.00	Medium Hard	49.20
4	R-52(a)	<i>Adjai Second</i>												
		Sijua Mixed Seam ...	20/80	2.50	15.16	25.70	13	19.04	0.85	76/02	45.45	78.00	"	50.00
5	R-40	<i>Damra</i>												
		Sijua Mixed Seam ...	20/80	2.00	14.84	26.10	12	19.34	0.82	73/80	54.54	80.00	Hard	48.71
6	R-40	<i>Chapuikhas</i>												
		Murulidih ...	20/80	3.20	15.02	34.23	12	22.00	1.00	78/08	31.81	80.50	"	50.52
		Begonia ...	100	3.00	14.18	20.32	13	20.02	0.04	76/02	47.73	83.00	"	47.90
7	R-37	Begonia ...	100	4.10	14.34	23.64	12	20.10	1.14	80/02	43.18	79.50	Med. Hard	49.74
8	R-44	Begonia ...	100	1.20	14.62	28.12	13	20.42	1.12	84/06	59.00	80.00	Hard	46.11
9	R-65(b)	Begonia ...	100	1.20	14.62	28.12	13	20.42	1.12	84/06	59.00	80.00	Hard	46.11
10	R-41	<i>Setalpur</i>												
		Sijua Mixed Seam ...	30/70	3.00	15.46	26.24	13	20.20	1.04	72/87	50.00	80.00	"	40.74
11	R-42(a)	<i>Setalpur</i>												
		Laikdih ...	30/70	2.25	13.82	30.28	14	18.92	1.02	70/00	54.91	78.00	Med. Hard	48.30
12	R-40(b)	<i>Setalpur</i>												
		M. C. Coal ...	30/70	2.80	17.62	27.40	13	23.64	0.96	70/82	40.01	80.00	Hard	47.50
13	R-25	<i>Palmohana</i>												
		Sijua 12 Seam ...	15/85	1.60	16.10	24.38	13	22.30	0.02	62/84	61.36	82.00	"	44.30
14	R-61(a)	<i>Central Kajora</i>												
		Sijua Mixed Seam ...	20/80	3.30	14.44	24.32	12	21.80	0.05	82/06	50.00	70.00	Med. Hard	48.43
15	R-60	<i>Central Kajora</i>												
		Laikdih ...	20/80	4.30	12.70	30.10	14	17.12	1.46	66/00	47.73	81.00	Hard	48.14
16	R-56	<i>Samla Ramnagar</i>												
		Sijua Mixed Seam ...	20/80	4.25	14.50	25.68	12	18.86	1.04	70/88	45.46	81.00	"	48.71
17	R-23	<i>New Satgram</i>												
		Sijua 12 Seam ...	15/85	1.80	16.50	24.28	13	21.90	0.86	74/88	63.63	82.00	"	44.00
18	R-62	<i>New Satgram</i>												
		Laikdih ...	20/80	3.55	14.00	20.26	15	19.00	0.89	76/02	47.73	83.00	"	49.48
19	LS-3†	<i>Setalpur</i>												
		Mixed Charging Coal...	30/70	6.10	16.76	28.10	15	23.08	0.82	75/02	50.00	80.70	"	45.45
20	LS-4	<i>Begonia</i>												
		M. C. Coal ...	30/70	3.70	17.42	25.21	13	23.45	0.82	80.3/03.6	57.57	80.30	"	41.09
21	LS-5	<i>Badjna</i>												
		Laikdih ...	30/70	4.32	14.31	26.52	14	18.65	0.56	71.3/80.6	46.07	75.00	Med. Hard	44.13
22	LS-6	<i>Begonia</i>												
		Laikdih ...	100	2.70	15.60	29.48	13	21.88	0.88	84.5/04.35	48.86	80.50	Hard	45.27

(a) High stability, fairly satisfactory result. (b) Confirmed by large-scale test.

\* R = Experiments carried out in the Russell Oven.

† LS = Experiments carried out in the full-size commercial ovens.

TABLE No. 4a — PARTICULARS OF COALS FROM THE CENTRAL PROVINCES (INCLUDING KOREA & REWA STATES)

SERIAL No.	COLLIERY	PARTICULARS OF THE SEAM			SECTION FROM WHICH SAMPLE TAKEN
		Number	Thickness	Extent	
1	Jhagrakhand	Jhagrakhand	...	...	...
2	Jhagrakhand	Jhagrakhand	...	...	...
3	Kurasia	3	...	...	...
4	Kurasia ( R/mine )	Pench Valley	...	...	...
5	Kurasia	...	...	...	...
6	do	1	...	...	...
7	do	2	...	...	...
8	do	2	...	...	...
9	Kurasia ( R/mine )	Gorghela	...	...	...
10	Newton Chikli	Pench Valley	...	...	...
11	do ( Rubble )	do	...	...	...
12	Palachoury	Bottom	...	...	...
13	do ( R/mine )	do	3'-6" sec.	...	...
14	New Chirmiri ( Pondri Hill )	...	B.I. sec.	...	...
15	do	...	B.I. sec.	...	...
16	New Chirimiri	Pondri Hill	...	...	...
17	New Chirimiri Hingir Rampur	...	...	...	...
18	Rakhikol	...	...	...	...
19	Hirdagarh	...	Abt. 10'	Over 48 acres	Full thickness of the seam without any rejection.
20	Sastj ( H.E.H. the Nizam's State )	...	34'-11"	Not stated	Sample representative of 8'-6" of bottom seam only, excluding a total of 9" of shale bands.
21	Rajur	...	7'-4½"	2100 ft. along the Dip & 4000 ft. along the Strike.	Full thickness of the seam excluding 7 bands of iron pyrites—Dip 31 SL off 19L ( N ).
22	Damua	...	11½' to 12'	580-50 acres	From 8'-3" of the lower portion of the seam ( as is being extracted in the 1st working stage ) leaving out a shale band of 6" width ).
23	Kalichhapar	...	11½' to 12'	937-86 acres	From 8'-3" of the bottom seam ( as is being extracted in 1st working stage leaving out a shale band of 4" width ).
24	Burhar ( Rewa State )	...	14'	3,788,744 acres	From the entire seam—foot by foot, excluding a shale band of 9".
25	Umaria ( Rewa State )	...	No. 2 Sm. 6'-7" No. 3 Sm. 9'-11"	Throughout South Rewa State	Mixed sample from the two seams, representative of the production of the colliery. Collected from picking belt on the surface.

**TABLE No. 4b — PROXIMATE ANALYSIS, ETC., OF COALS FROM CENTRAL PROVINCES  
(INCLUDING KOREA & REWA STATES)**

Sl. No.*	PROXIMATE ANALYSIS — %				TOTAL SULPHUR %	PHOS. IN COAL %	CAKING INDEX	SWELLING TEST		FUSION RANGE OF ASH DEG. C.	COLOUR OF ASH	ULTIMATE ANALYSIS (DRY)				B.Th.U.
	Moisture	Dry						Koppers	Nedelmann's Pressure lb./sq. in.			Carbon %	Hydrogen %	Nitrogen %	Oxygen %	
		Ash	V.M.	F.C.												
1	4.60	13.24	33.50	53.26	0.480	0.010	N.C.	harmless	...	1390 — 1430	Brick-red	...	not done	...	...	11,920
2	3.80	15.06	31.92	52.12	0.464	0.012	4	"	...	1390 — 1420	Cream	...	"	...	...	11,530
3	3.00	16.16	34.40	49.44	0.359	0.012	N.C.	"	...	1250 — 1280	Reddish-brown	...	"	...	...	11,240
4	5.20	16.84	34.08	49.08	0.368	0.010	1	"	...	1370 — 1400	Brown	...	"	...	...	11,760
5	6.80	9.60	37.00	53.40	0.685	0.014	2	"	...	1410 — 1440	Pinkish	...	"	...	...	12,240
6	8.50	11.26	40.30	48.44	0.700	0.038	3	"	...	1400 — 1450	Pink	...	"	...	...	12,080
7	6.00	12.02	38.30	49.68	0.535	0.078	2	"	...	1380 — 1430	Brick-red	...	"	...	...	11,780
8	5.40	11.28	33.64	55.08	0.564	0.104	N.C.	"	...	1330 — 1360	Pinkish	...	"	...	...	11,980
9	7.07	16.45	32.01	51.54	0.398	0.025	"	"	...	1410 — 1430	Reddish-brown	67.88	4.70	1.46	9.19	11,081
10	4.80	17.70	38.10	44.20	1.685	0.034	"	"	...	1220 — 1250	Brick-red	...	not done	...	...	10,760
11	4.20	20.12	36.00	43.88	0.929	0.011	"	"	...	1230 — 1270	Grey	...	"	...	...	10,389
12	4.20	17.50	33.10	49.40	0.500	0.011	"	"	...	1380 — 1420	Buff	...	"	...	...	11,470
13	3.80	38.50	27.23	34.27	0.328	0.027	"	"	...	1260 — 1300	Cream	...	"	...	...	8,080
14	4.80	22.32	28.66	49.02	0.384	Traces	"	"	...	1420 — 1460	Brick-red	...	"	...	...	10,380
15	5.60	11.60	34.82	53.58	1.104	"	2	"	...	1130 — 1170	Brown	...	"	...	...	12,050
16	6.60	17.05	31.84	51.11	0.260	0.012	N.C.	"	...	Above 1430	Pink	...	"	...	...	11,180
17	...	18.84	34.94	46.22	...	...	...	"	...	...	...	...	"	...	...	10,710
18	2.70	20.56	28.30	51.14	1.730	Traces	13	"	0.58	1370	Reddish-brown	64.37	4.06	1.37	7.91	10,501
19	2.10	20.76	32.46	46.78	0.398	0.040	9	"	No press. developed	Over 1400	Brown	65.16	4.71	1.46	7.51	not done
20	10.80	13.80	35.90	50.30	1.080	Traces	N.C.	"	"	1380 — 1430	Greyish	...	...	1.39	...	"
21	16.00	16.92	35.12	47.96	0.985	"	"	"	"	Over 1450	White	...	...	1.44	...	"
22	3.60	14.15	30.31	55.54	0.740	0.020	11	"	0.31	Over 1400	Brown	...	...	1.44	...	"
23	2.95	18.47	29.59	51.94	0.700	0.03	11	"	0.66	1340 — 1370	Brown	...	...	1.50	...	"
24	7.30	16.86	34.46	48.68	0.448	Traces	N.C.	"	No press. developed	Over 1430	Cream	62.99	4.48	1.44	13.78	"
25	10.30	18.60	28.70	52.70	0.273	Traces	"	"	"	Over 1400	White	59.32	4.72	1.13	16.95	"

\* Refer to corresponding serial numbers in Table No. 4a.  
N.C. = Non-coking.



TABLE No. 4c — RESULTS OF THE SCREEN ANALYSIS OF THE COALS FROM THE CENTRAL PROVINCES & REWA STATE

SERIAL No.	COLLIERY	ON 2" SCREEN			BETWEEN 2" & 1"			BETWEEN 1" & ½"			BETWEEN ½" & ¼"			BETWEEN ¼" & 30 MESH			BETWEEN 30 & 60 MESH			BELOW 60 MESH					
		Wt. %	Ash %	C.I.	Wt. %	Ash %	C.I.	Wt. %	Ash %	C.I.	Wt. %	Ash %	C.I.	Wt. %	Ash %	C.I.	Wt. %	Ash %	C.I.	Wt. %	Ash %	C.I.			
1	Hirdagarh ...	47.50	20.72	...	37.25	20.42	...	8.00	20.22	...	1.00	19.48	...	0.50	19.62	...	2.00	26.68	...	0.88	27.44	...	0.87	30.10	...
2	Sasti ( H.E.H. the Nizam's State)	...	...	...	18.00	14.64	...	31.00	15.04	...	28.50	14.00	...	11.00	13.56	...	11.50	12.72	...	2.00	18.46	...	3.00	15.28	...
3	Hirdagarh ( Rakhikol)	13.00	26.84	11	64.00	17.02	11	14.50	25.88	13	4.50	26.10	12	2.00	19.82	14	1.37	16.12	14	0.25	18.62	13	0.38	27.56	13
4	Kurasia ( Kurasia State)	...	...	...	52.40	15.62	...	33.80	13.00	...	9.70	13.44	...	2.80	13.96	...	0.80	15.02	...	0.20	31.00	...	0.30	42.14	...
5	Rajur ...	...	...	...	0.09	16.36	...	36.74	18.36	...	29.54	17.12	...	13.62	17.12	...	13.57	15.56	...	2.43	15.04	...	4.01	14.80	...
6	Damua ...	...	...	...	8.50	14.88	11	51.50	15.24	11	20.50	14.00	11	8.50	12.90	12	7.50	11.78	13	1.50	12.24	13	2.00	21.60	10
7	Kalichhapar ...	...	...	...	15.50	22.22	11	50.00	19.42	10	17.00	18.22	11	8.00	17.18	11	7.50	16.40	13	1.25	16.88	12	0.75	23.90	10
8	Burbar ( Rewa State)	...	...	...	...	...	...	...	...	...	...	...	...	...	...	...	...	...	...	...	...	...	...	...	...
9	Umaria ( Rewa State)	35.25	17.54	...	50.00	19.70	...	8.25	17.20	...	3.00	18.04	...	1.25	15.88	...	1.25	16.68	...	0.50	16.64	...	0.50	17.90	...

TABLE No. 4d — RESULTS OF LABORATORY BLENDING TESTS WITH COALS FROM THE CENTRAL PROVINCES, KOREA & REWA STATES

Sl. No.	COLLIERY	SEAM	PROXIMATE ANALYSIS			COKING PROPERTIES & COKING INDEX	LABORATORY BLENDING TEST RESULTS WITH COKING COALS								
			Ash %	V.M. %	F.C. %		TATA'S MIXED CHARGING	LOW VOLATILE			MEDIUM VOLATILE			HIGH VOLATILE	
								Sijua	Choitodih	Malkera	Ramnagar	Chanch	West Bokaro	Bhatdee	Murulidih
1	Damua	...	14.15	30.31	50.54	semi-coking—11	20	10	not done	50(a)	...	not done	30		
2	Kalichhapar	...	18.47	29.59	51.04	do	20	10	"	50(a)	...	"	20		
3	Hirdagarh	...	20.76	32.46	46.78	do	20	20	"	40(a)	...	"	20		
4	Jhagrakhand	...	13.24	33.50	53.26	non-coking	not done	10—20	20	20	10	10	10	N	
5	Kurasia	... 3	16.16	34.40	49.44	do	"	10—20	10	10	10	N	10	10	
6	Newton Chikhl	... Pench Valley	17.70	38.10	44.20	do	"	10—20	20	20	10	10	N	10	
7	Palachoury	...	17.50	33.10	49.40	do	"	10—20	10	20	10	N	10	N	
8	New Chirimiri (Pondri Hill)	... Sec. B-1	22.32	26.66	49.02	do	"	10	10	10	10	10	N	N	
9	do	... Sec. B-2	11.60	34.82	53.58	do	2	"	20	10	10	10	10	10	
10	Kurasia	... 1	11.26	40.30	48.44	do	3	"	10—20	10	20	10	N	10	
11	Kurasia	... 2	12.02	38.30	49.68	do	2	"	10—20	20	20	10	N	10	
12	Hingir Rampur	...	15.70	36.40	47.90	do	"	10—20	20	20	10	N	10	10	
13	Kurasia	... Gorghela	16.45	32.01	51.54	do	10	10	10	20	20	10(b)	10	...	
14	Sasti	...	13.80	35.90	50.30	non-caking	10	10	not done	30(a)	...	not done	10		
15	Rajur	...	16.92	35.12	47.96	do	10	10	"	30(a)	...	"	20		
16	Burhar	...	16.86	34.46	48.68	do	10	10	"	30(a)	...	"	20		
17	Umaria	...	18.60	28.70	52.70	do	10	10	"	30(a)	...	"	10		

(a) Tested with Laikdih.

(b) Also with Laikdih — 10.

N=Not even 10 per cent of the test coal was found usable.

**TABLE No. 4e — PROXIMATE ANALYSIS OF COKING COALS USED FOR LABORATORY BLENDING TESTS WITH  
CENTRAL PROVINCES & REWA COALS**

SERIAL No.	COLLIERY	SEAM No.	PROX. ANALYSIS ( DRY ) %			CAKING INDEX	REMARKS
			Ash	Volatile Matter	Fixed Carbon		
1	Mixed Charging Coal from Tata's Coke Ovens	...	17.60	25.27	57.13	14/15	
2	do	...	17.94	24.68	57.38	15	Used with Gorghela seam coal only.
3	Sijua 12 seam	... 12	13.32	28.56	58.12	15	
4	do	... 12	16.78	23.48	59.74	15	Used with Gorghela seam coal only.
5	do	... 14	17.24	24.56	58.20	15	
6	do	... 14	13.90	23.18	62.92	15	Used with Gorghela seam coal only.
7	do	... 16	18.12	25.92	55.96	15	Used with Gorghela seam coal only.
8	do	... 16	16.64	28.36	55.00	17	
9	Malkera	... 13, 14, 15	17.04	25.46	57.50	16	
10	Choitodih	... 13, 14, 15	15.46	24.86	59.68	16	
11	do	... 13, 14, 15	19.08	24.82	56.10	15	Used with Gorghela seam coal only.
12	Murulidih	... Mobuda Bottom	15.40	35.46	49.14	15	
13	Bhatdee	... do	17.90	34.50	47.60	15	Used with Gorghela seam coal only.
14	do	... do	13.14	35.08	51.78	16	
15	Chanch	... Chanch	15.70	31.24	53.06	16	
16	do	... do	17.77	30.13	52.10	14	Used with Gorghela seam coal only.
17	Raunagar	... Laikdih Bottom	12.76	30.04	57.20	16	
18	do	... do	13.48	29.52	57.00	17	Used with Gorghela seam coal only.
19	Laikdih	... Laikdih Deep	16.22	28.84	54.94	15	Used with Gorghela seam coal only.
20	West Bokaro	... 9	17.40	26.20	56.40	13	
21	do	... 10	13.15	31.18	55.67	15	

TABLE No. 4f — SUMMARY OF RESULTS OF SEMI-LARGE-SCALE & LARGE-SCALE TESTS WITH COALS FROM CENTRAL PROVINCES, KOREA & REWA STATES

SL. No.	EXPERIMENT No.	CHARGING BLEND.	PERCENTAGE OF BLEND	PROXIMATE ANALYSIS OF THE BLEND			CAKING INDEX	PROX. ANALYSIS OF COKE (DRY)		PHYSICAL TESTS OF COKE			QUALITY OF COKE	POROSITY %
				Moisture %	Dry			Ash %	V.M. %	Shatter Test Index 2 1/4"	Haven's Test Stability on 1"	Breslau's Test Total on 40 mm.		
					Ash %	V.M. %								
1	S-34	Newton Chikli—West Bokaro (10 seam)	10/90	1.60	14.20	30.68	14	19.76	3.12	81/93	45.05	80.5	Hard	44.57
2	S-91	New Chirimiri—M.C. Coal ...	10/90	1.60	17.58	26.04	13	21.34	2.84	87/93	46.59	80.25	"	45.50
3	S-89	Newton Chikli—M.C. Coal ...	10/90	1.70	18.20	26.00	13	22.00	2.36	86/95	52.27	80.00	"	45.02
4	S-94(a)	Kurasia (R/mine)—M.C. Coal ...	10/90	2.40	17.10	25.22	13	21.70	2.22	88.5/94	45.45	78.50	Med. hard	45.02
5	S-46(a)	New Chirimiri—West Bokaro ...	10/90	2.50	18.68	30.98	14	18.40	3.79	73/83.5	51.40	79.00	"	45.10
6	S-93	Kurasia 1 seam—M.C. Coal ...	10/90	1.60	16.20	26.96	14	21.50	2.36	86/90	46.59	79.50	"	44.04
7	S-95	Kurasia 2 seam—M.C. Coal ...	10/90	1.80	16.24	26.08	14	21.50	2.54	87/94	55.68	78.25	"	40.21
8	S-35	Hingir Rampur—Sijua 14 seam ...	20/80	1.90	15.16	25.30	13	18.36	3.87	85/95	49.42	82.00	Hard	44.70
9	S-33	Hingir Rampur—West Bokaro (10 seam)	10/90	2.30	13.92	30.92	15	18.54	3.38	76/91	47.72	80.00	"	45.06
10	S-144(a)	Jhagrakhand—Sijua 12 seam	20/80	2.60	16.00	24.76	13	21.08	2.56	81/91.5	45.45	79.00	Med. hard	40.31
11	S-110(a)	Jhagrakhand—Choitodib, 13, 14, 15, seam.	20/80	2.00	18.56	24.80	14	23.48	2.68	87/90.5	50.00	79.00	"	43.08
12	R-8(a)	Jhagrakhand—Bhatdee ...	10/90	3.20	17.04	33.80	12	24.74	1.76	80/94	54.54	78.00	"	50.20
13	R-9	Kurasia (R/mine)—Sijua 16 seam	10/90	2.40	17.64	25.48	13	23.18	1.68	84/92	45.45	78.00	"	44.90
14	R-7	Kurasia (R/mine)—Sijua 12 seam	10/90	3.10	16.64	24.80	14	21.44	1.44	76/90	50.00	81.00	Hard	47.60
15	R-12(a)	Newton Chikli—Sijua 12 seam ...	10/90	4.60	17.00	24.48	14	22.40	1.38	84/94	56.82	79.00	Med. hard	47.60
16	R-14(a)	New Chirimiri—Sijua 12 seam ...	10/90	3.90	14.30	24.30	14	19.40	1.40	68/86	56.82	79.00	"	47.40
17	S-130	New Chirimiri—Sijua 12 seam ...	10/90	3.40	16.68	24.20	14	19.28	2.00	86/95	63.63	85.00	Hard	45.20
18	S-100	New Chirimiri—Choitodib, 13, 14, 15 seam.	20/80	2.10	18.86	26.08	13	24.60	2.40	85/90	45.45	80.25	"	44.04
19	S-127	Kurasia, 1 seam—Sijua 12 seam	10/90	4.20	15.94	24.86	14	19.96	2.30	88/93.5	65.91	84.00	"	48.90
20	S-112(a)	Hingir Rampur—Sijua 12 seam	10/90	2.00	16.26	24.40	13	20.28	2.62	84/92	48.56	79.00	Med. hard	46.04
21	S-111	Hingir Rampur—Choitodib, 13, 14, 15	10/90	2.40	18.96	25.68	13	23.44	2.18	91/95.5	45.50	80.00	Hard	41.49
22	S-73(a)	Gorghela—Ramnagar ...	15/85	1.30	13.30	30.7*	15	18.08	2.18	84.5/92.5	48.86	77.50	Med. hard	46.56
23	S-85	Gorghela—Laikdih ...	15/85	1.25	15.16	30.48	13	20.42	2.00	89/96	51.13	83.50	Hard	42.70
24	S-104	Gorghela—Sijua 12 seam ...	15/85	1.60	16.44	24.76	13	20.12	2.36	82.5/92	63.53	83.50	"	43.15
25	R-5(a)	Gorghela—Sijua 14 seam ...	15/85	4.00	13.98	24.62	13	19.24	1.68	74.5/88.5	53.40	76.75	Med. hard	43.08
26	S-88	Gorghela—Sijua 16 seam ...	15/85	1.50	18.22	26.14	13	20.82	2.40	92/96.5	52.27	83.00	Hard	45.60
27	S-103	Gorghela—Choitodib, 13, 14, 15	10/90	1.75	18.46	25.24	14	22.48	2.08	82.5/95	60.02	81.00	Hard	41.31
28	S-86(b)	Gorghela—M.C. Coal ...	10/90	1.20	17.66	26.46	14	22.00	2.12	84/91.5	53.40	81.50	Hard	41.80
29	S-87	Gorghela—M.C. Coal ...	20/80	1.20	17.40	26.90	13	20.44	2.32	84/92.5	54.40	82.75	"	42.60
30	R-11(c)	Rakhikol ...	100	5.00	21.38	27.98	12	27.96*	1.48	80/88	47.73	77.00	Med. hard	49.00
31	S-118	Rakhikol—Gorghela—M.C. Coal	40/15/45	3.20	18.40	27.24	13	23.14	2.68	87/94	49.32	80.25	Hard	45.31
32	LS-1	Gorghela—M.C. Coal ...	15/85 †	5.00	17.20	26.10	13	21.70	1.80	78/92	45.45	76.00	Med. hard	40.60
33	LS-2	Rakhikol—Gorghela—M.C. Coal	40/15/45	4.80	18.52	27.88	13	23.96†	0.98	81.5/93	56.81	76.00	"	42.02

\* Sulphur 1.15%. † Might prove suitable with some relaxation in the specification of physical properties of coke. ‡ Sulphur 0.91%.

a) High stability; fairly satisfactory coke. (b) Confirmatory large-scale test was carried out with 15% of the test coal.  
 (c) Both ash and sulph. contents excessive, quality of coke also unsatisfactory.

S = Experiments carried out in the Swoboda Oven.  
 R = Experiments carried out in the Russell Oven.  
 LS = Experiments carried out in full size commercial ovens.

TABLE No. 5a — PROXIMATE ANALYSIS OF COALS FROM SOUTH KARANPURA, HYDERABAD ( DECCAN ),  
MADRAS, ASSAM & AUSTRALIA

Sl. No.*	PROX. ANALYSIS %				TOTAL S %	P IN COAL %	C.I.	SWELLING TEST		FUSION RANGE OF ASH DEG. C.	COLOUR OF ASH	ULTIMATE ANALYSIS ( DRY )				B.T.H. U./LB.	SOFTENING POINT OF COAL DEG. C.
	Moisture	Dry						Koppers	Nedelmann's Pressure lb./sq. in.			C	H	N	O		
		Ash	V.M.	F.C.													
1	2.37	16.00	35.10	48.81	0.420	0.132	6	Harmless	...	1310—1340	...	...	...	...	12,320	...	
2	10.20	13.40	35.30	51.30	0.486	Traces	N.C.	"	...	1425	Reddish-brown	66.35	3.90	1.26	14.514	11,164	405
3	5.40	14.28	35.94	49.78	0.741	"	"	N	...	1465	White	66.71	4.28	1.37	12.619	10,862	...
4	12.30	5.84	49.46	44.70	0.846	"	"	Usual shrinkage	N.P.		Deep cream	64.74	4.49	1.04	23.04	10,842	Did not soften at any point
5	2.1	5.54	44.10	50.36	3.514	Trace	14	Harmless	0.193	1180—1170	Grey	73.53	5.58	1.40	10.44	...	...
6	1.5	18.54	38.80	42.66	8.71	"	13	"	0.246	1340—1370	Grey	...	...	0.66	...	...	...
7	4.5	7.59	41.80	50.61	5.98	"	N.C.	"	N.P.	1220—1280	Deep chocolate	...	...	0.94	...	...	...
8	2.4	12.88	25.98	61.14	0.486	"	16	Doubtful	2.30	1410	Greenish-white	73.12	4.41	1.39	7.714	13,063	...
9	1.2	10.68	25.72	63.62	0.285	0.055	16	Harmless	...	1415	Cream	77.26	4.33	1.25	6.215	13,667	...
10	1.6	12.10	25.14	62.76	0.208	0.046	16	"	...	1380	Cream	75.41	4.32	1.20	6.672	13,340	...
11	1.2	10.06	26.22	63.72	0.364	0.022	16	"	1.16	Over 1500	White	78.05	4.38	1.19	5.956	13,818	390
12	1.8	11.00	25.62	63.38	0.368	0.028	16	"	...	1470	White	74.75	4.29	1.36	8.232	13,582	...

N.C. = Non-caking.

N.P. = No pressure developed.

\*1 Sirka ( South Karanpura )

2 Kothagudium, Grade A ( Hyderabad, Deccan )

3 Tandur, Grade A ( " )

4 Madras, Lignite

5 Namdang, Baragolai ( Assam )

6 Cherrapunji ( " )

7 Dilli ( " )

8 Wongawilli Cleaned ( Australia )

9 Bulli ( Large ) ( Australia )

10 Bulli ( Smalls ) ( " )

11 Mt. Kembla ( Large ) ( " )

12 Mt. Kembla ( Smalls ) ( " )

TABLE No. 5b — RESULTS OF SCREEN ANALYSIS OF COALS FROM HYDERABAD ( DECCAN ), MADRAS, ASSAM & AUSTRALIA COALFIELDS

Sl. No.	COLLIERY	ON SCREEN			BETWEEN 2" & 1"			BETWEEN 1" & ½"			BETWEEN ½" & ¼"			BETWEEN ¼" & 30 MESH			BETWEEN 30 & 60 MESH			BELOW 60 MESH					
		Wt. %	Ash %	C.I.	Wt. %	Ash %	C.I.	Wt. %	Ash %	C.I.	Wt. %	Ash %	C.I.	Wt. %	Ash %	C.I.	Wt. %	Ash %	C.I.	Wt. %	Ash %	C.I.			
HYDERABAD ( Deccan )																									
1	Kothagudium ...	2.50	15.00	NC	44.50	15.68	NC	27.00	12.78	NC	11.50	12.04	NC	5.00	12.00	NC	7.00	13.06	NC	0.80	14.84	NC	1.70	16.72	NC
2	Tandur ...	28.50	14.14	"	38.00	14.60	"	14.00	14.70	"	6.50	13.34	"	3.50	13.50	"	6.40	13.20	"	1.10	14.42	"	2.00	17.00	"
3	MADRAS ...	57.15	4.00	...	29.50	5.30	...	6.12	4.00	...	3.08	5.00	...	1.02	5.00	...	2.04	6.20	...	0.51	8.24	...	0.51	10.72	...
ASSAM																									
4	Namdang Baragolai ...	5.50	8.30	...	13.50	4.90	...	19.50	7.10	...	18.00	5.10	...	12.50	5.30	...	24.50	4.23	...	3.50	5.80	...	3.00	0.63	...
5	Cherrapunji ...	32.73	16.60	12	25.46	17.12	11	15.00	21.72	12	10.00	18.72	14	5.45	18.30	13	15.45	18.64	13	0.91	20.40	15	5.00	26.50	16
6	Dilli ...	15.50	11.36	NC	16.50	7.00	NC	19.00	5.50	NC	12.00	6.04	NC	9.00	6.04	NC	14.50	5.40	NC	0.00	5.84	NC	4.50	10.46	NC
AUSTRALIA																									
7	Wongawilli ( cleaned ) ...	...	...	...	...	...	...	1.25	17.40	15	17.50	16.42	16	17.50	16.80	16	53.20	12.64	17	6.05	12.00	17	4.50	14.72	17
8	Bulli ( large ) ...	...	...	...	9.75	9.28	12	55.00	9.30	13	23.75	13.46	14	7.50	11.50	16	7.70	10.76	17	1.00	9.36	17	1.30	11.23	17
9	Bulli ( small ) ...	...	...	...	...	...	...	45.00	15.00	12	25.00	16.70	13	10.00	16.56	15	12.70	12.14	17	2.80	10.98	17	4.80	13.36	17
10	Mt. Kembla ( large ) ...	...	...	...	10.00	9.20	13	57.50	10.28	15	15.00	10.80	16	7.50	10.76	16	6.80	10.08	16	1.30	9.12	17	1.00	10.86	17
11	Mt. Kembla ( small ) ...	...	...	...	7.50	10.80	13	25.00	11.00	13	17.50	13.50	14	15.00	12.70	15	28.80	10.76	16	4.10	9.64	16	4.10	12.48	17

62

TABLE No. 5c — RESULTS OF LABORATORY BLENDING TESTS OF COALS FROM SOUTH KARANPURA, HYDERABAD ( DECCAN ) & MADRAS COALFIELDS

COLLIERY	SEAM	PROX. ANALYSIS — DRY		COKING PROPERTIES & COKING INDEX	LABORATORY BLENDING TEST RESULTS WITH COKING COALS *																			
		V.M. %	F.C. %		TATA'S MIXED CHARGING	LOW VOLATILE			MEDIUM VOLATILE			HIGH VOLATILE												
						Sijua	Choitodih	Malkera	Ramnagar	Chanch	West Bokaro	Bhatdee	Muruldih											
SOUTH KARANPURA																								
Sirka ...	...		35.10	Poor-caking — 6	10	10	10	10	N20†	10	10	10	...											
HYDERABAD ( Deccan )																								
Kothagudium ...	A.Gr.	13.40	35.30	Non-caking	10	10	N	...	20	...	...	N	...											
Tandur ...	"	14.28	35.94	"	10	10	N	...	20	...	...	N	...											
MADRAS ...	...	5.84	49.46	"	N	...	...	...	10	...	...	...	...											

\* The figures indicate the maximum percentage of the test coals usable in blends with coking coals to yield satisfactory result. — For analysis of coking coals, see Table No. 5d.

† With Laikdih.

N = Not even 10 per cent of the test coal was found suitable.

**TABLE No. 5d — PROXIMATE ANALYSIS OF COKING COALS USED FOR LABORATORY BLENDING TESTS  
WITH COALS FROM SOUTH KARANPURA, HYDERABAD (DECCAN) & MADRAS COALFIELDS**

COLLIERY	SEAM	PROX. ANALYSIS ( DRY ) %			COKING INDEX	REMARKS
		Ash	Volatile matter	Fixed Carbon		
Sijua	12	16.07	23.02	50.91	15	Used with Kothagudium and Tandur coals.
do	14	13.98	23.04	63.08	15	do
do	14	14.80	22.28	62.92	15	Used with Sirka coal.
do	16	18.80	26.32	54.88	15	Used with Kothagudium and Tandur coals.
Choitodih	13, 14, 15	19.14	24.70	56.10	15	do
Ramnagar Bottom	Laikdih	13.84	29.42	56.74	16	do
do	do	13.86	28.10	58.04	17	Used with Sirka coal.
Bhatdee	Mohuda Bottom	17.40	34.10	48.50	14	Used with Kothagudium and Tandur coals.
do	do	17.18	33.82	49.00	15	Used with Sirka coal.
Laikdih	Laikdih	16.69	27.37	65.94	15	do
do	do	13.18	27.92	53.90	17	Used with Madras coal.
Chanch	Chanch	17.70	30.94	51.36	14	Used with Sirka coal.
Tata's C.O. Mixed Charging coal	...	17.59	24.95	57.46	14	do
Tata's C.O. Mixed Charging coal	...	18.30	24.68	57.02	15	Used with Madras coal.

TABLE No: 5e — SUMMARY OF RESULTS OF SEMI-LARGE-SCALE TESTS WITH SOUTH KARANPURA (SIRKA), HYDERABAD (DECCAN) & AUSTRALIAN COALS — SATISFACTORY RESULTS

SL. No.	EXPERIMENT No.	CHARGING BLEND	PERCENTAGE OF BLEND	PROXIMATE ANALYSIS OF THE BLEND			CAKING INDEX	PROX. ANALYSIS OF COKE (DRY)		PHYSICAL TESTS OF COKE			QUALITY OF COKE	POROSITY %
				Moisture %	Dry %			Ash %	V.M. %	Shatter Test Index 2"/1 1/2"	Haven's Test Stability on 1"	Breslau's Test Total on 40 mm.		
					Ash	V.M.								
SOUTH KARANPURA (SIRKA) COAL														
1	S-79*	Sirka Sijua 14 seam ...	10/90	1.25	15.12	23.56	15	18.56	2.35	84/93	63.63	87.75	Very hard	41.07
2	S-82	Sirka Sijua 14 seam ...	20/80	1.24	14.82	22.88	14	17.77	2.20	85/96	61.36	84.50	Hard	41.08
3	S-83(a)	Sirka Ramnagar ...	10/90	1.20	13.94	29.38	16	17.24	2.55	79.5/91	47.72	79.25	Med. hard	43.06
4	S-77	Sirka Laikdih ...	10/90	1.20	16.82	27.22	15	21.41	2.50	81/93.5	55.68	81.50	Hard	42.09
5	S-81(g)	Sirka Laikdih ...	20/80	1.30	16.56	29.18	14	20.17	2.14	88/94	47.73	79.75	Med. hard	45.08
6	S-75	Sirka M.C. Coal ...	10/90	1.10	16.44	25.58	14	21.38	2.11	86/92.5	55.68	81.00	Hard	45.00
7	S-76	Sirka M.C. Coal ...	16/85	1.00	16.22	26.10	14	21.74	2.31	84/93.5	51.13	80.50	Hard	44.70
8	S-80	Sirka M.C. Coal ...	20/80	1.85	16.02	25.50	18	21.51	2.36	80/90	45.45	81.25	Hard	41.50
HYDERABAD (DECCAN) COALS														
9	R-16(a)†	Kothagudium Sijua 14 seam ...	10/90	3.60	13.86	24.56	14	19.14	1.36	80/91	63.36	79.00	Med. hard	40.1
10	R-13	Kothagudium Sijua 12 seam ...	10/90	3.80	16.50	24.50	14	21.20	1.36	75/92	54.54	80.00	Hard	48.0
11	R-18(a)	Kothagudium M.C. Coal ...	10/90	3.90	17.06	26.18	15	21.30	1.48	82/92	59.09	76.00	Med. hard	47.4
12	R-17(a)	Tandur Sijua 14 seam ...	10/90	4.20	13.98	24.56	14	19.60	1.68	76/92	63.63	77.00	Med. hard	46.9
13	R-15(a)	Tandur Sijua 12 seam ...	10/90	4.20	16.18	24.50	14	21.38	1.48	76/87	61.36	76.00	Med. hard	48.5
14	S-126	Tandur M.C. Coal ...	10/90	3.80	17.40	26.30	14	22.48	2.34	86/95	59.09	83.00	Hard	44.6
AUSTRALIAN COALS														
15	S-122(a)	Bulli (large and small)	100	1.20	11.60	25.46	16	15.00	2.16	83/92	54.54	78.00	Med. hard	44.50
16	S-124(b)	Mt. Kemia	100	3.80	10.58	25.88	16	15.14	2.00	85/93	61.36	80.00	Hard	47.00
17	S-125	Wongawillii (cleaned)	100	4.60	13.42	25.92	16	18.60	2.40	82/91	59.09	83.50	Hard	49.72

S = Experiments carried out in Swoboda Oven.  
R = Experiments carried out in Russell Oven.  
(a) High stability factor; fairly satisfactory result.  
(b) Low ash content, a special feature.



**TABLE No. 6 — SUMMARY OF RESULTS OF ALL SEMI-LARGE-SCALE TESTS CARRIED OUT WITH JHARIA & RANIGANJ COALS FOR THE PRODUCTION OF LOW ASH COKE**

SL. EXPERIMENT No.	No.	CHARGING BLEND	PERCENTAGE OF BLEND	PROXIMATE ANALYSIS OF THE BLEND			CAKING INDEX	PROX. ANALYSIS OF COKE ( DRY )		PHYSICAL TEST OF COKE			QUALITY OF COKE	POROSITY %
				Moisture %	Dry %			Ash %	V.M. %	Shatter Test Index 2"/14"	Haven's Test Stability on 1"	Breslau's Test Total on 40 mm.		
					Ash	V.M.								
1	S-18(a)	Laikdih Deep ( Laikdih seam )	25	2.10	13.77	28.60	16	18.73	2.08	86.5/95	48.86	84.75	Hard	44.44
		Bararee 14, 14A & 15	25											
		Sijua 12 & 14	25											
2	S-19(a)	Laikdih Deep ( Laikdih seam )	30	2.20	13.07	28.70	16	19.66	1.14	75.5/93	55.12	82.75	Hard	43.94
		Kustore 15	30											
		Bararee 14, 14A & 15	20											
3	S-20(b)	Bararee 14, 14A, 15	50	2.20	12.30	31.85	14	16.12	2.80	82.5/90.5	33.23	75.75	Med. hard	43.30
		Sripur Poniat ( Poniat seam )	50											
4	S-24	Bararee, 14, 14A, 15	50	2.20	13.13	29.22	17	17.76	2.66	78/92	62.05	80.87	Hard	45.20
		Laikdih Deep ( Laikdih seam )	50											

(a) Ash content of coke is rather high. It is otherwise satisfactory.

(b) Both stability factor and Abrasion test results are poor. Coke unsatisfactory.

65

**TABLE No. 7—SUMMARY OF RESULTS OF SEMI-LARGE-SCALE TESTS WITH BLENDS OF COKE-BREEZE & MIXED CHARGING COAL FROM TATA'S COKE OVENS \***

A few typical results showing the influence of grain size and proportion of coke-breeze

SL. EXPERIMENT No.	No.	CHARGING BLEND	PERCENTAGE OF BLEND	PROXIMATE ANALYSIS OF THE BLEND			CAKING INDEX	PROX. ANALYSIS OF COKE ( DRY )		PHYSICAL TEST OF COKE			QUALITY OF COKE	POROSITY %
				Moisture %	Dry %			Ash %	V.M. %	Shatter Test Index 2"/14"	Haven's Test Stability on 1"	Breslau's Test Total on 40 mm.		
					Ash	V.M.								
1	S-7	M.C. Coal Coke-breeze ground	99/1	3.30	18.74	27.44	15	22.92	2.44	86/92	40.90	80.00	Hard	42.29
2	S-17	M.C. Coal Coke-breeze ground	98.5 1.5	1.80	18.00	25.48	13	23.04	2.06	87.5/93	37.50	80.25	Hard	44.73
3	S-21	M.C. Coal Coke-breeze ground	98/2	2.70	15.64	24.22	15	22.87	2.21	84.2/91.5	42.04	82.50	Hard	40.20
4	S-22	M.C. Coal (a) Coke-breeze ground	97.5 2.5	1.90	17.54	24.66	13	22.39	2.20	84/91	33.20	78.00	Med. hard	43.00
5	S-13	M.C. Coal (a) Coke-breeze ground	97/3	3.20	16.94	26.50	15	22.64	3.26	91/94	31.80	79.70	Med. hard	45.10
6	S-27	M.C. Coal (a) Coke-breeze ground	96/4	1.10	17.80	24.92	15	21.39	3.28	85/87.2	34.66	73.25	Soft	42.70
7	S-14	M.C. Coal (b) Coke-breeze ground	99/1	2.80	17.08	26.26	15	23.24	3.97	84/91	25.00	68.50	Very soft	41.80

\*All experiments were carried out in the Swoboda Oven. (a) Use of coke-breeze in higher percentage than 2 yielded poor coke. (b) Unground coke-breeze yielded poor coke.

TABLE No. 8 — SUMMARY OF RESULTS OF SEMI-LARGE-SCALE TESTS CARRIED OUT IN THE RUSSELL OVEN WITH MIXED CHARGING COALS FROM TATA'S COKE OVENS — TO STUDY THE REPRODUCIBILITY OF TEST RESULTS & STANDARDIZE OPERATING CONDITIONS

Sl. No.	EXPT. No.	CHARGING BLEND	PERCENTAGE OF BLEND	PROX. ANALYSIS OF THE BLEND			C.I.	PROX. ANALYSIS OF COKE (DRY)		PHYSICAL TEST OF COKE			QUALITY OF COKE	POROSITY %	CARBONIZATION PERIOD HR. MIN.	AVERAGE FLUE TEMP. DEG. C.	OVEN WALL TEMP. BEF. CHARGING DEG. C.	COKE MASS TEMP. BEFORE RAKING
				Moisture %	Dry %			Ash %	V.M. %	Shatter Test Index 2"/1 1/4"	Haven's Test Stability on 1"	Breslau's Test Total on 40 mm.						
					Ash	V.M.												
1	R-34*	M.C. Coal from coke ovens	100	3.5	17.80	24.76	15	22.46	0.90	68/90	43.18	72.00	Soft	46.70	14—45	1150	891	979
2	R-35	do	100	3.00	17.80	24.98	16	21.92	0.96	69/87	38.63	73.00	Soft	45.90	14—35	1160	891	941
		Average of 10 days commercial operation	...	4.50	17.85	24.43	15	22.63	0.78	79/91	46.59	82.81	Hard	42.30	19—30	1220	1010	...
3	R-38†	M.C. Coal from coke ovens	100	3.20	17.60	24.82	15	23.10	0.96	78/92	47.73	81.00	Hard	46.70	12—00	1055	805	854
4	R-39‡	do	100	3.40	17.64	24.76	15	23.10	0.98	74/90	50.00	80.00	Hard	46.50	12—00	1045	805	835
		Average of 10 days commercial operation	...	4.27	17.81	24.33	15	22.76	0.66	78/91	47.72	82.30	Hard	42.50	19—30	1220	1010	...

\* The quality of coke was poorer than that from commercial ovens.

† The quality of coke was similar to that from commercial ovens.

‡ Percentage of porosity of coke from test ovens is generally higher than that from commercial ovens.

TABLE No. 9 — RESULTS OF SWELLING TESTS CARRIED OUT IN THE SWOBODA OVEN

SERIAL No.	EXPERIMENT No.	COAL OR BLEND TESTED	BLEND PER CENT	SWELLING PRESSURE TEST		Indications from Koppers Laboratory apparatus
				Maximum pressure recorded in lb./sq. in. in Swoboda Oven Test	Maximum pressure indicated in lb./sq. in. in Nedelmann's apparatus	
1	S-1	Kankanee ... ..	100	1.35	1.20	Harmless
2	S-2	Bhuggutdih ... ..	100	1.27	1.70	do
3	S-3	Khas Jharia ... ..	100	0.847	1.56	do
4	S-4	Khas Jharia ( Repeat ) ... ..	100	0.805	1.56	do
5	S-142	Central Nandi ... ..	100	0.670	0.330	do
6	S-138	Begonia ... ..	100	0.420	(i)* 0.350 (ii) 0.730	do
7	S-145	Seetalpur ... ..	100	0.690	(i)* 0.970 (ii) 0.080	do
8	S-141	Jote Janakikhas ... ..	100	No press. developed	0.230	do
9	S-143	New Satgram ... ..	100	No press. developed	(i)* 0.310 (ii) 0.120	do
10	S-144	Kuardih ... ..	100	0.590	0.078	do
11	S-130	Khas Angarpatra ( Jharia ) ... ..	100	0.840	0.500	do
12	S-134	Banksimulla/Laikdih ... ..	15/85	0.700	...	do
13	S-131	Damra/Laikdih ... ..	15/85	No press. developed	...	do
14	S-135	Damra/Mixed Charging ... ..	10/90	No press. developed.	...	do
15	S-140	Begonia/Mixed Charging ... ..	50/50	1.010	...	do
16	S-137	Seetalpur/Mixed Charging ... ..	30/70	1.010	...	do
17	S-133	Patmohana/Sijua 12 seam ... ..	15/85	1.430	...	do
18	S-132	Samla/Laikdih ... ..	10/90	1.260	...	do
19	S-136	Samla/Mixed Charging ... ..	10/90	0.600	...	do

N.B.—Maximum safe limit for Swoboda ... 2.00 lb./sq. in.  
 " " " for Nedelmann ... 14.22 lb./sq. in.

\* Two experiments were done in the Nedelmann's apparatus with samples from two different consignments of the same coal.